

AXEMEN

AXEMEN POWER EQUIPMENT

OWNER'S MANUAL

INSTRUCTIONS FOR ASSEMBLY, TESTING, OPERATION,
SERVICING AND STORAGE

AIR COMPRESSOR: OUTDOOR AGRICULTURAL PRODUCT
USED FOR GENERAL PURPOSE



AIR COMPRESSOR

TAC81M



WARNING:



READ and UNDERSTAND the Owner's Manual completely before using this air compressor.

Assemble, test and use only in accordance with the Owner's Manual instructions.

WEAR personal protective gear when filling, using, cleaning, and servicing the air compressor.

DO NOT START the air compressor until you have read, understood, and followed the instructions in this manual.

Improper use of the air compressor could result in serious injury or illness to the operator or nearby persons/animals, and cause property damage.

Welcome

Thank you for your purchase of this quality AXEMEN POWER, Inc. product. We wish you years of success using your new air compressor.

This manual contains general warnings about the inherent risks of operating air compressors and specific warnings about the operation and maintenance of this particular air compressor. In addition, it outlines important maintenance and storage procedures.

Please read it carefully before operating, maintaining, repairing, and storing your new air compressor. Keep this owner's manual handy so you can refer to it at any time. This owner's manual is considered a permanent part of the air compressor and should remain with the air compressor if resold.

The information and specifications included in this publication were in effect at the time of approval for printing. AXEMEN POWER, Inc. reserves the right, however, to discontinue or change specifications or design at any time without notice and without incurring any obligation whatsoever. No part of this publication may be reproduced without written permission.

Thank you for your business.

Customer service

Consult an Authorized Service Dealer regarding maintenance or repair procedures.

Please contact us with service-related questions regarding operating and assembling your new air compressor, including parts you may be missing.

Customer support: 1-888-929-3468

Support@axemenpower.com

www.Axemenpower.com

Retain for your records

Record your air compressor's model number and serial number as well as the date you purchased the air compressor below.

Retain this information for your records. You'll need to refer to this information when ordering parts and contacting customer service about maintaining your air compressor and its warranty.

Model number:

Serial number:

Date purchased:

_____ Month _____ Day _____ Year

TAC81M Nameplate

PRODUCT INFORMATION		
COMPRESSOR	Model	TAC81M
	Work Pressure	90 PSI
	Max Pressure	115 PSI
	Tank	8 Gallon Twin
	Air Flow	16.54 CFM @ 90 PSI
ENGINE	Engine Model	KOHLER SH265-3000
	Speed (rpm)	3000 - 3300
	Displacement (cc)	196
	Max. Output (Kw)	4.9
	Max. Torque (N-m)	11.5 N-m @ 2800 rpm
	Engine Serial No.	

AXEMEN
AXEMEN POWER EQUIPMENT
TEL: (888) 929-3468
www.axemenpower.com

Contents

Welcome 1

Customer service 1

Retain for your records 2

Important safety precautions 5

Air Compressor Safety 6

Carbon Monoxide WARNINGS 9

Burn and fire WARNINGS 10

About your air compressor 10

Reference manual contains critical information 10

What’s in the Box? 11

Air Compressor Major Components and Controls Diagram 12

Engine Major Components and Controls Diagram 13

Engine Controls 14

Initial Set-Up 14

Pre-operation check 17

Are you ready to get started? 17

Is your Air Compressor read to go? 18

Fuel and Oil Requirements 20

Fuel Requirements 20

Oil requirements 20

Monitoring the fuel level 21

Using caution when refueling the tank 22

Inspect Fuel System/Check for Leaks 22

Operation 23

Air Compressor Placement 23

Air Hose and Tool Use 25

Attaching Air Hose and Tools 26

Using Compressor for Spraying 26

Shutdown Procedures 27

Maintenance 28

Importance of maintenance 28

Maintenance safety precautions 28

Air Compressor Maintenance Schedule 29

Detailed Instructions – Maintenance & Repair 30

Inspect Safety/Relief Valve 31

Inspect Air Filter 31

Inspect Compressor for Air Leaks 31

Engine Maintenance 31

Change Pump Oil 32

Inspect & Clean Spark Arrestor (If equipped) 33

Keep Compressor Clean 33

Between-Use Storage..... 34

Draining the Tank: 35

Long Term Storage Preparation 35

Troubleshooting 36

Air compressor specifications: 40

Engine assembly and parts list: 41

Contact information for Technical and Customer Assistance 41

Locate an Authorized Service Dealer 41

Customer assistance 41

Limited Warranty..... 43

Appendix A: Lubricants and Compatibility 45

Important safety precautions

This manual contains critical safety information. Please read the entire manual closely.

Because safety is paramount and using an air compressor carries significant responsibilities, we have outlined warnings and the general hazards of operating air compressors. In addition, we have summarized the recommended procedures for operating, repairing, maintaining, and storing your specific air compressor to keep you and others safe.

Not following instructions or using poor judgment when using and maintaining your air compressor can cause you or someone else to be **KILLED** or **SERIOUSLY INJURED**.

It would be impossible for us to warn you of each risk and all of the hazards involved in the use of air compressors. Therefore, it's essential that you use your best judgment and take precautions when using, maintaining, repairing, and storing your air compressor.

There are many safety warnings in this manual and on the air compressor itself to guide you:

Air compressor safety labels: The safety labels on your air compressor warn of potential danger. It's critical that you read them. If any labels become difficult to read or have been removed, contact your dealer for a replacement label.

Manual safety messages: This manual contains specific instructions and severe warnings about the ramifications of using poor judgment and not following the instructions outlined in this manual. The ramifications range from serious injury and losing consciousness to death. These messages are preceded by a safety alert symbol  and one of three signal words, DANGER, WARNING, or CAUTION.

These signal words mean:



You **WILL** be **KILLED** or **SERIOUSLY HURT** if you don't follow instructions



You **CAN** be **KILLED** or **SERIOUSLY HURT** if you don't follow instructions



You **CAN** be **HURT** if you don't follow instructions



Manual headings and sections: We've devoted several sections of this manual to outline the risks, hazards, and warnings when using, repairing, maintaining, and storing your air compressor.

Instructions: how to use this Air Compressor correctly and safely.

Pay attention to cautions such as, "**Carbon monoxide WARNINGS**" or "**Burn and fire WARNINGS.**"



Read manual before operating unit

 WARNING: SPECIAL HAZARDS 	
<ul style="list-style-type: none">• CO Poisoning: Exhaust from engine contains carbon monoxide, a poisonous gas that can cause carbon monoxide poisoning and possible death if inhaled.• Injection Injury: High pressure air stream can pierce skin and underlying tissue, leading to serious injury and possible amputation. Such an injection injury can result in blood poisoning and/or severe tissue damage.• Flying Debris: High-pressure air stream can cause flying debris and possible surface damage.• Electric Shock: Operating equipment in wet conditions or near water can cause electric shock.• Not For Breathing Air: AXEMEN Power Inc. compressors are NOT designed, intended, or approved for supplying breathing air. No compressed air should be used for breathing unless air is treated in accordance with applicable standards.• Fire/Explosion: Sparks from air powered tool heads or attachments can ignite fuel or other flammable liquids or vapors in the vicinity. Exceeding the maximum pressure for air tools or attachments could cause them to explode.• Burns: Compressor pump, engine, and discharge tubing are hot surfaces that can cause burn injuries.	
<p>* Detailed safety information about these hazards appears throughout this manual.</p>	

Important Safety Information

AXEMEN POWER air compressors are designed to provide compressed air primarily used for operating air tools and pressurizing other non-tool objects such as tires. Special precautions are necessary when used for cleaning. This compressor is NOT to be used to supply breathing air.

Note: Do not use for other purposes, as unforeseen hazards or equipment damage may result.

Most injuries or property damage can be prevented if you follow all instructions in this manual and on the air compressor. The most common hazards are discussed below, along with the best way to protect yourself and others.

Operators Responsibility

It is the operator's responsibility to provide the necessary safeguards to protect people and property. Know how to stop the air compressor quickly in case of emergency. If you leave the air compressor for any reason, always turn the engine off. Understand the use of all controls and connections.

Adult Control ONLY: Only trained adults should set up and operate the air compressor. Be sure that anyone who operates the air compressor receives proper instruction. Do not let children operate the air compressor. Keep children and pets away from the area of operation.

Personal Protection: Wear safety apparel during operation, including safety glasses with side and top protection. Ear protection is also recommended if working near any operating engine.

Under the influence: Never operate, or let anyone else operate, the air compressor while fatigued or under the influence of alcohol, drugs, or medication.

* Keep this manual for reference and review.

Air Compressor Operation

This air compressor is intended for outdoor use only.

This compressor is powered by a gasoline engine and therefore can only be operated outdoors.

This air compressor will require you to supply and install the following fluids and equipment:

- Compressor pump oil (as specified)
- Gasoline (as specified)
- Engine Oil (as specified)
- Personal Protection Equipment

* See “Specifications” section of this manual for more details.

Refuel With Care

Gasoline is extremely flammable, and gasoline vapor can explode. Refuel outdoors, in a well-ventilated area, with the engine stopped and the air compressor on a level surface. Do not fill the fuel tank above the fuel strainer shoulder. Never smoke near gasoline, and keep other flames and sparks away. Remember, always store gasoline in an approved container. Make sure that any spilled fuel has been wiped up before starting the engine.

Hot Exhaust

The muffler becomes very hot during operation and remains hot for a while after stopping the engine. Be careful not to touch the muffler while it is hot. Let the engine cool down before transporting the air compressor or storing it indoors.

To prevent fire hazards, keep the air compressor at least 7 feet (2 meter) away from building walls and other equipment during operation. Do not place flammable objects close to the engine.

Carbon Monoxide Hazard

Exhaust contains poisonous carbon monoxide, a colorless and odorless gas. Breathing carbon monoxide can cause loss of consciousness and may lead to death.

If you run the air compressor in an area that is confined, or even partly enclosed, the air you breathe could contain a dangerous amount of exhaust gas.

Never run the engine inside a closed garage, house, or confined area.



NOTICE:



ATTENTION: Rental Companies and Private Owners who loan this equipment to others!

- All persons to whom you rent/loan this air compressor must have access to and read this manual. Keep this owner's manual with the air compressor at all times and advise all persons who will operate the machine to read and understand it. You must also provide personal instruction on how to safely set-up and operate the air compressor and remain available to answer any questions a renter/borrower might have. Owner's manuals are available from AXEMEN Power Customer Support at 1-888-929-3468 or Support@Axemenpower.com

Carbon Monoxide WARNINGS

The exhaust from your air compressor contains carbon monoxide. Breathing this poisonous gas, which is odorless and colorless, can cause unconsciousness and could even kill you.

Only operate your air compressor outdoors.

Operating an air compressor carries serious responsibility. There are precautions that you need to take when operating an air compressor:

- Never operate your air compressor indoors or near any windows or doors.
- Never operate your air compressor in an enclosed or a partially enclosed area such as a garage.
- Do not let the exhaust from your air compressor build up to dangerous levels.
- Do not breathe the poisonous gas in your air compressor's exhaust.
- Become familiar with your air compressor. Understand all of your air compressor's controls, connections, and outputs. Know how to quickly stop your air compressor in case of an emergency.
- If anyone else operates your air compressor, be sure he/she is properly instructed.
- Do not let children play with or operate your air compressor.
- Keep your air compressor at least three feet away from flammable materials.

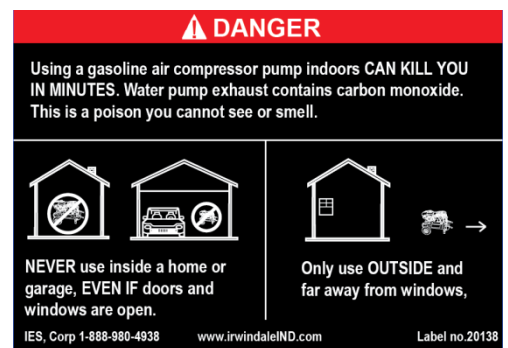

	WARNING:	
The engine exhaust from this product contains chemicals known to the State of California to cause cancer, birth defects or other reproductive harm.		

Burn and fire WARNINGS

Your air compressor's exhaust system becomes hot enough that it could ignite some materials and cause severe burns.

Gasoline is highly flammable and can be explosive, so use extreme caution when refueling and operating your air

- Stop engine when refueling.
- Do not smoke when refueling your air compressor.
- Keep your air compressor at least seven feet (or 2 meters) away from buildings and equipment.
- Keep flammable materials away from your air compressor.
- Do not allow sparks or flames near your air compressor when it's refueled and keep them away from your stored gasoline.
- Fuel vapors are highly flammable, so they could ignite after your air compressor is started. Wipe up any spilled fuel before you restart your air compressor.
- Do not operate your air compressor in enclosed or partially enclosed areas.
- Avoid touching your air compressor's muffler. It becomes extremely hot when your air compressor is in use. It remains hot for quite a while after you turn your air compressor off, so wait to move your air compressor into storage until the muffler has completely cooled to avoid severe burns.

About your air compressor

Reference manual contains critical information

It's recommended that you keep this Owner's Manual near your air compressor, so you can refer to it while operating and maintaining it. If you resell your air compressor, this manual is considered to be a part of the air compressor and should be passed along with it to the new owner.

The information contained in this manual as well as the specifications outlined in it were in effect upon approval for publishing this manual. AXEMEN Power Inc. reserves the right to change the specifications and instructions. AXEMEN Power Inc. also reserves the right to discontinue and modify the design of the air compressor at any point without incurring any obligation and without providing notice. This document may not be reproduced in whole or in part without written permission from AXEMEN Power Inc.

Attention: All Rental Companies and Private Owners who loan this equipment to others!

All persons to whom you rent/loan this air compressor must have access to and read this manual. Keep this owner’s manual with the air compressor at all times and advise all persons who will operate the machine to read it. You must also provide personal instruction on how to safely operate the air compressor and be available to answer any questions a renter/borrower might have.

This air compressor is a machine designed for outdoor air compressor applications primarily used in the operation of air tools and pressurizing other non-tool objects such as tires. Special precautions are necessary when using this compressor for cleaning applications. It is not to be used to supply breathing air.

The technical specifications for your air compressor are provided in the “Specifications” section of this manual.

What’s in the Box?

Below is a summary of the components included in your air compressor set. It’s recommended that you review the items listed below and confirm they were all included in your purchase.

Name of Component	Quantity
Air Cooled Air compressor	1
Owner’s Manual	1
Engine Manual	1

Air Compressor Major Components and Controls Diagram

Below are diagrams of your air compressor's major components and controls:

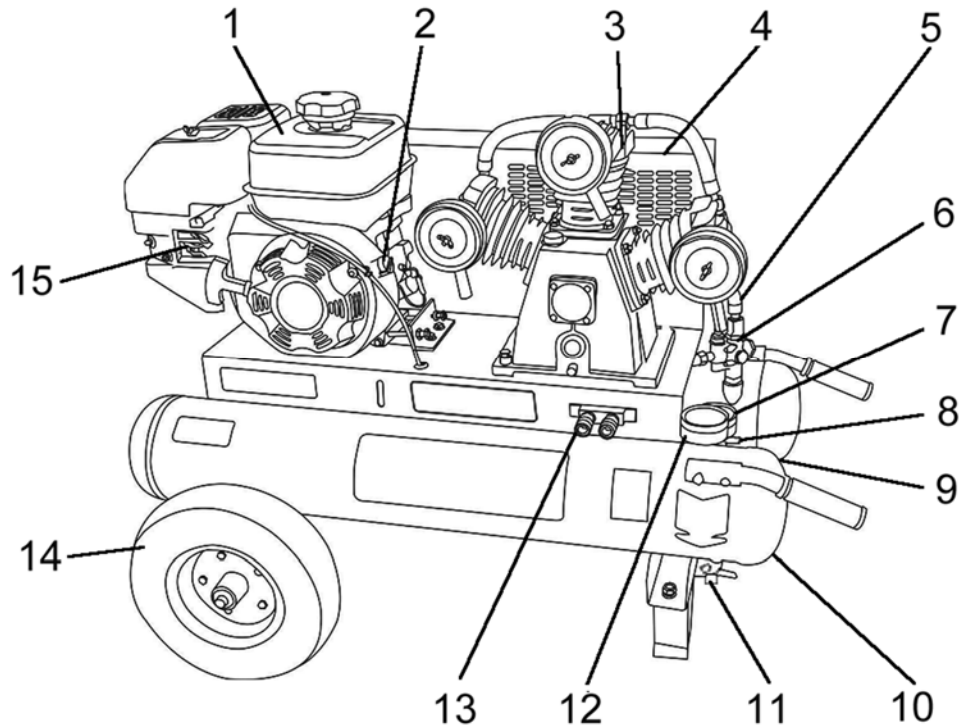

1. Engine: NOT shipped with oil. Refer to engine Owner's Manual for proper oil and capacity.

2. Engine On/Off Switch: Turn switch to "ON" when starting engine. CAUTION: Unit is not equipped with high temperature "auto shutoff". Do NOT allow to overheat.

3. Compressor Air Filter: Keep clean and particle free. See "Pump Explosion and Pump Parts List" for replacement part number.

4. Belt Guard: Covers belt, engine pulley and flywheel. NEVER operate compressor without belt guard in place.

5. Discharge Tube: Carries compressed air from pump to safety/check valve, and then to the storage tank. It becomes very hot during use and can cause severe burns. Never touch.

6. Unloader: Vents discharge air to atmosphere in constant speed or start/stop operation.

7. Regulated Pressure Gauge: Liquid filled gauge. Shows regulated supply pressure.

8. Regulator: Adjusts outlet pressure, not to exceed pressure rating of attachment tool.

9. ASME Safety/Check Valve: Automatically releases air if tank exceeds preset pressure max. 150 PSI. A check valve is a pressure release port. Pull valve pin to relieve pressure from receiver tank.

10. Air Receiver / Storage Tank: 8 gallon twin tank.

11. Tank Drain Valve: Used to remove moisture from air after compressor is shut off and air emptied from tank. Drain moisture daily after each use.

12. Tank Pressure Gauge: Liquid filled gauge. Shows pressure in receiver tank.

13. Quick Connect: This is a 1/4" quick connect.

14. Pneumatic Tires: Keep tire pressure at 30 PSI for easy movement.

15. Engine Controls: Location of choke, engine speed and fuel valve.

Engine Major Components and Controls Diagram

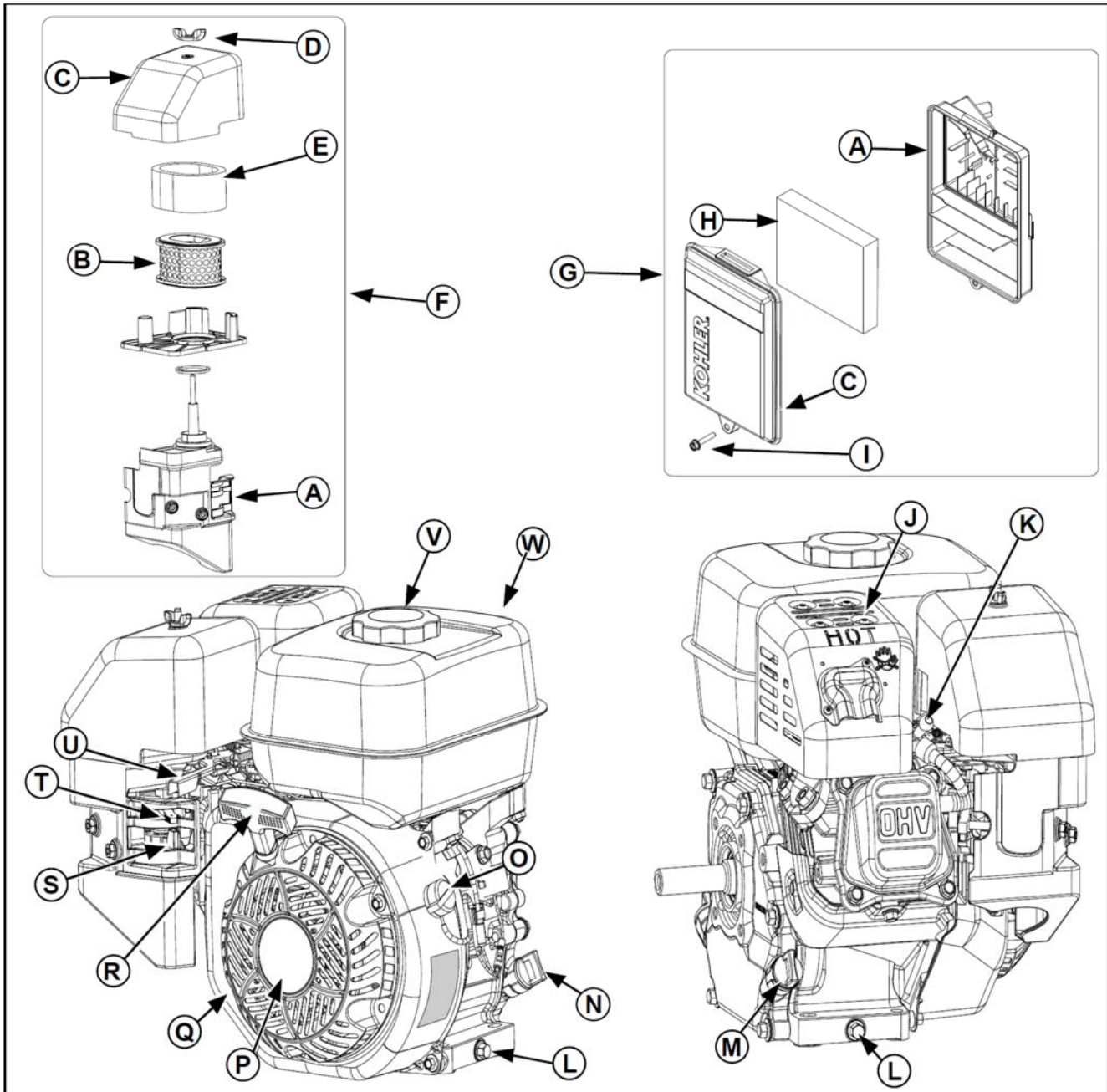

A	Air Cleaner Base	B	Paper Element	C	Air Cleaner Cover	D	Wing Nut
E	Precleaner	F	Dual-Element Air Cleaner	G	Low-Profile Air Cleaner	H	Foam Element
I	Screw	J	Muffer Shield	K	Spark Plug	L	Oil Drain Plug
M	Oil Fill Plug	N	Dipstick	O	On/Off Switch (if equipped)	P	Retractable Starter
Q	Debris Screen	R	Starter Handle	S	Fuel Shut-Off	T	Choke Control
U	Throttle Control	V	Fuel Cap	W	Fuel Tank		

Engine Controls

Fuel Shut Off

The fuel shut off valve opens and closes the connection between the fuel tank and the carburetor. The fuel shut off valve lever must be in the ON position for the engine to run. When the engine is not in use, leave the fuel valve lever in the OFF position to prevent flooding and to reduce the possibility of fuel leaks.

On/Off Switch

The ignition On/Off switch controls the ignition system. The ignition switch must be in the ON position for the engine to run. Turning the ignition switch to the OFF position stops the engine.

Choke Control

The choke control lever opens and closes the choke valve in the carburetor. The CLOSED position enriches the fuel mixture for starting a cold engine. The OPEN position provides the correct fuel mixture for operation after starting, and for restarting a warm engine.

Auto Throttle Control

This air compressor utilizes an auto throttle solenoid to control the engine speed. The operator should not adjust the throttle or engine speed.

Starting Handle

Pulling the starting handle operates the recoil starter to crank the engine for starting.

Oil Sentry (if equipped)

This switch is designed to prevent engine from starting in low oil or no oil condition. Oil Sentry may not shut down a running engine before damage occurs. In some applications this switch may activate a warning signal.

Initial Set-Up

Air Compressor: Wheels and Feet Installation

Inspect contents:

Please inspect your unit for any missing parts or damage to the unit. Also, verify that the unit in your possession is the unit you have ordered.

See "component Identification" section of this manual for a diagram of the compressor and its full list of components.

- For **missing components**, contact AXEMEN Power Support at 1-888-929-3468.
- For **damage components**, contact the freight company that delivered the unit and file a claim.
- If **complete**, fill out the product serial number information. See Limited Warranty section of this manual.

For Outdoor Use ONLY

Select a suitable outdoor location:

- Where it will NOT be exposed to rain, snow, or direct sunlight.
- Where no flammable vapors, dust, and gases are present.
- At least 7 feet away from combustible materials.
- Away from building windows or other air intakes.
- Away from other heat generating equipment.
- Away from dusty/dirty conditions

Poisoning: The air compressor should be mounted on a dry, firm, and level surface. It must sit level and be stabilized so it will not slide or shift during operation.

- Situate so there is adequate pulling room for starting the engine using the recoil starter. Attempting to pull at an odd angle could rip off grip cord and/or cause muscular injuries to the operator.

Airflow:

- The location should allow for adequate, unobstructed airflow for cooling and combustion air.
- Do not allow debris to accumulate or block airflow.
- Do not operate with a tarp, blanket, or cover surrounding the machine.
- Do not place any objects against or on top of the unit.

Exhaust:

WARNING: Exhaust Modification Hazard

Never attempt to attach ductwork to the muffler system to allow for installation inside an enclosure. This could cause heat build-up and increased exhaust back-pressure, resulting in possible exhaust leakage or damage to the compressor.

DANGER: Carbon Monoxide Hazard

Exhaust fumes from the engine contain carbon monoxide (CO), a poisonous gas you cannot see, smell, or taste. The CO generated by the engine can rapidly accumulate, even in areas that appear to be well ventilated, resulting in dangerous and fatal concentrations within minutes. NEVER run air inside any enclosed or semi-enclosed spaces, including homes, garages, basements, sheds, boxes, pick-up truck beds, RV's, or boats. These spaces can trap poisonous gases, EVEN if you run a fan or open windows. If you start to feel sick, dizzy, or weak while using the air compressor, shut off the engine and get to fresh air RIGHT AWAY. See a doctor. You may have carbon monoxide poisoning.

- Place the unit so that the exhaust fumes will not be directed towards people or building air intakes.
- Keep a fire extinguisher rated “ABC” nearby which is properly charged. Be familiar with its use.
- Provide battery-operated or battery back-up type carbon monoxide alarms in a structure that is in close proximity to the running compressor.
- Do not install in small, enclosed areas without an ample circulation of supply air.

Ideal operating temperatures:

- 40° to 100° F (4° to 37° C)

Operating Limitations:

- 15° F (-9° C) or above 125° F (52° C)

If temperatures consistently drop below 32° F (0° C), store inside a heated building. If this is not possible, protect the safety/relief and drain valves from freezing.

Note: In frequently humid areas, moisture may form in the pump and produce sludge in the oil, causing parts to wear out prematurely. Excessive moisture is likely to occur if unit is stored in an unheated area subject to large temperature changes.

Two signs of excessive humidity are external condensation on the pump when it cools down and a “milky” appearance in pump oil.

Install Spark Arrestor (if Required)

Equip engine with spark arrestor if machine will be used near any ignitable forest, brush, or grassy land. (See engine Owner’s Manual provided to determine if the engine is already equipped.) Make sure you comply with applicable local, state, and federal codes.

Installing Air Discharge Hose/Piping

If installing discharge piping you must:

- Adhere to all local building codes.
- Use discharge piping of the same diameter as the compressor discharge connection.
- Use pipe, tube, hose, or distribution components rated for use with compressed air and maximum pressure of this compressor.
- Use a properly rated flexible connection between the tank and discharge piping.

 WARNING: Burst Hazard 
<p>Do not use plastic (PVC) pipe, rubber hose, copper, or lead-tin solder joints anywhere in the compressed air system.</p>

Pre-operation check

Are you ready to get started?



Your safety is your responsibility. A little time spent in preparation will significantly reduce your risk of injury.

Knowledge

Read and understand this manual. Know what the controls do and how to operate them.

Familiarize yourself with the air compressor and its operation before you begin using it. Know what to do in case of emergencies.

Before starting the compressor, review the safety rules found below and throughout the manual.

 WARNING: 
READ and UNDERSTAND <u>this owner's manual</u> completely before using the air compressor. <i>Improper use of the air compressor could result in serious injury or illness for the operator or nearby persons/animals, or cause damage to the environment. Failure to follow safety rules may result in serious injury or death to the operator or bystanders.</i>

Instruct Operators

Owner must instruct all operators in safe set-up and operation. Do not allow anyone to operate the compressor who has not read the Owner's Manual and been instructed on its safe use.

Safety Equipment/Controls

Always operate with all safety covers, guards, and barriers in place and in good working order, and all controls properly adjusted for safe operation.

Moving Parts

Keep hand, feet, hair and apparel away from moving parts. Air vents may cover moving parts and should be avoided as well. Never remove any guards while the unit is operating.

Ear Protection

Hearing can be damaged from prolonged, close-range exposure to the type of noise produced by this compressor. The use of ear plugs or other hearing protection device is recommended for persons working within 15-20 feet of the running compressor for an extended period of time.

Eye Protection



Wear ANSI/OSHA required "Z87.1" safety glasses when operating or servicing the compressor. Pressurized air spray from this unit can cause severe injury to the eyes. Small objects can become airborne as the air spray contacts them.

Respirator

Always wear a respirator when spraying and spray in a well-ventilated area to prevent health and fire hazards.

Is your Air Compressor ready to go?

For your safety, and to maximize the service life of your equipment, it is very important to take a few moments before you operate the air compressor to check its condition. Be sure to take care of any problem you find, or have your servicing dealer correct it, before you operate the air compressor. Make sure that any regular maintenance has been performed as described in "Maintenance and Repair" section.



 WARNING: 
Improperly maintaining this air compressor, or failure to correct a problem before operation, could cause a malfunction in which you could be seriously injured.
Always perform a pre-operation inspection before each operation, and correct any problem.

To prevent a possible fire, keep the Air Compressor at least 7 feet (2 meter) away from building walls and other equipment during operation. Do not place flammable objection close to the engine.

Before beginning your pre-operation checks, be sure the air compressor is on a level surface and the ignition switch is in the OFF position.

Check the General Condition of the air compressor

- Look around and underneath the air compressor for signs of oil or gasoline leaks.
- Remove any excessive dirt or debris, especially around the engine, muffler, and recoil starter.
- Look for signs of damage.
- Check that all nuts, bolts, screws, hose connectors, and clamps are tightened.
- Refer to the engine Owner's Manual for engine maintenance instructions.
- Check oil level in the engine. See engine owner's manual.
- Drain receiver tank of any moisture.
- Check for any unusual noise/vibration.
- Ensure the area around the compressor is free from rags, tools, debris, and flammable or explosive materials.
- Ensure belt guards and covers are securely in place.

 WARNING: Entanglement Hazard 
Do NOT operate with protective covers or guards removed. Doing so could expose high speed moving components which could allow for the operator or bystander to become entangled. Entanglement in this equipment may result in serious injury, amputation, or death.

Check/Add Oil to Engine and Pump

Check the oil levels in the engine and pump. Use dipstick for engine oil level and sight glass for pump oil level. Add oil as needed. A low oil shutdown feature prevents the engine from starting without sufficient oil.

Engine: See engine Owner's Manual for capacity and recommended oil type for your expected ambient conditions.

! WARNING: Burn Hazard !
Never open oil port while compressor is running. Hot oil can spray over face and body.

! CAUTION: Inadequate Lubrication Hazard !
Never operate compressor with inadequate lubricant. This will cause overheating and severe damage to the engine and pump.

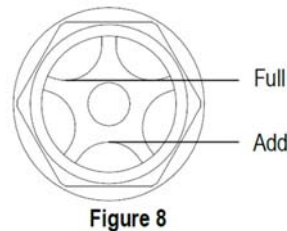
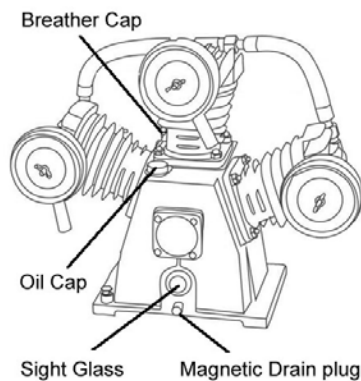

Figure 8
Sight Glass

The compressor pump capacity is 27 ounces use SAE 30 non-detergent pump oil prior to break-in. You may use synthetic lubricants after 50 hour break-in. See Appendix A: Lubricants and Compatibility for list of suitable and alternative lubricants. Remove the oil cap and fill the pump case with the appropriate oil to the Full level on the sight glass in Figure 8. Recheck the level after initial operation.

! CAUTION: Synthetic Lubrication Hazard !
If you will be using a synthetic lubricant, all downstream piping material and system components must be compatible.

Check the Engine

- Check the oil level (see engine manual). To avoid the inconvenience of an unexpected shutdown by the Oil Sentry system, always check the engine oil level before startup.
- Check the air filter (see engine manual). A dirty air filter will restrict air flow to the carburetor, reducing engine and Air Compressor performance.
- Check the fuel level (see monitoring fuel level in this manual). Starting with a full tank will help to eliminate or reduce operating interruptions for refueling.

Fuel and Oil Requirements

Fuel Requirements



Use only unleaded gasoline to help minimize combustion chamber deposits.

Use only clean gasoline and oil. Never use gasoline or oil that is stale, contaminated, or poor quality. This could damage your air compressor's engine. Keep your fuel tank and oil cup clear of impurities (e.g. dirt, dust, water).

Refer to the engine owner's manual for fuel specifications.

Any performance problems or damage to your air compressor's engine as a result of using fuels other than those recommended in the engine owner's manual are not covered under warranty.

Refer to the engine owner's manual for specific instructions on filling and/or refilling the fuel tank.

 WARNING: 	
Gasoline is highly flammable and explosive. You can be burned or seriously injured when handling fuel.	
<ul style="list-style-type: none">• Stop the engine and keep heat, sparks and flame away.• Handle fuel only outdoors.• Wipe up spills immediately.	



Oil requirements

Refer to the engine owner's manual for the type and quantity of the engine oil. Please check the temperature ranges and use the appropriate oil.

Do not run your air compressor without oil. This would damage the engine and void your warranty.

IMPORTANT NOTE!
Engine is shipped without engine oil! Before operation, engine must be filled with the appropriate type and quantity of oil as specified by the engine manufacturer. Damage to the engine will result in running the engine without the proper type and quantity of oil. The warranty does NOT cover engine damage as a result of operation the engine without oil as specified by the manufacturer. Please refer to the engine owner's manual for the type, quantity and proper method for filling the engine with oil.

Monitoring the fuel level

		WARNING
	<p>Explosive Fuel can cause fires and severe burns. Do not fill the fuel tank while the engine is hot or running.</p>	

DO NOT OVERFILL FUEL TANK

When adding fuel, turn the air compressor engine off and let it cool at least 2 minutes before removing the gas cap. Make sure the engine is cool before proceeding.

After the engine is cool, remove the fuel tank cap and check the fuel level.

Refill the fuel tank if the fuel level is low but do not fill above the upper level mark "A" in figure 5.

Refer to the engine owner's manual for special warnings and detailed instruction on refueling the engine.

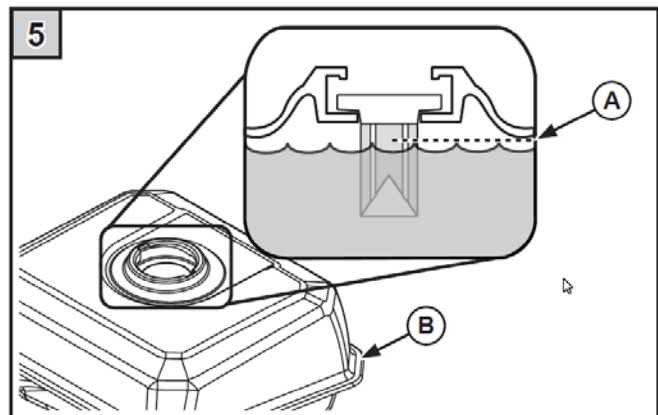

WARNING: Fire/Explosion Hazard



Gasoline is highly flammable and explosive. Heat, sparks, and flames can ignite gasoline vapors, which can become widespread during fueling. A flash fire and/or explosion could result and cause serious injury or death. Use extreme care when handling gasoline. Carefully follow all the instructions in this section to avoid the following conditions which could result in gasoline ignition:

- Gas vapor collection inside enclosures.
- Static electric sparks.
- Sparks from electric wiring, batteries, or running engines.
- Sources of heat (such as hot engine or exhaust).
- Open flames, including pilot lights.
- Smoking.



WARNING: Hot Engine Hazard



A running engine is hot enough to ignite fuel. Never add fuel or remove gas cap if engine is running or still hot. Let cool more than 2 minutes or longer until engine is cool before opening gas cap.

Using caution when refueling the tank

Fuel Outdoors: Fill fuel tank outdoors – never indoors. Fuel vapor is highly flammable and could ignite after your air compressor is started.

Use approved container: Never fuel the compressor directly into engine fuel tank at a gas station. Static charge can build and ignite fuel. Use an UL approved fuel container with a capacity of 2 gallons or less to transfer gas to the engine.

Clean up any spills: After refueling, wipe up any spilled fuel before restarting your air compressor. Fuel vapors may ignite or explode, fuel spills must be cleaned up before starting. Fuel can damage components of your air compressor such as metal, rubber, paint, and plastic.

- If possible move machine away from spilled gas on the ground.
- Wipe up spilled gas and wait for 5 minutes for excess gas to evaporate before starting engine.
- Gas-soaked rags are flammable and should be disposed of properly.
- If gas is spilled on your skin or clothes, change clothes and wash hands immediately.

Note: Damage caused by spilled fuel is not covered under warranty.

Inspect Fuel System/Check for Leaks

- Inspect fuel system for leaks BEFORE starting compressor. Look for:
- Signs of leaks or deterioration
- Chafed or spongy fuel hose
- Loose connections
- Loose or missing fuel hose clamps
- Damaged gasoline tank
- Selective gasoline shut-off valve

Do NOT start compressor until all needed repairs have been completed.

Operation

Air Compressor Placement

For Outdoor Use ONLY



DANGER: Carbon Monoxide Hazard



Exhaust fumes from the engine contain carbon monoxide (CO), a poisonous gas you cannot see, smell, or taste. The CO generated by the engine can rapidly accumulate, even in areas that appear to be well ventilated, resulting in dangerous and fatal concentrations within minutes. NEVER run air inside any enclosed or semi-enclosed spaces, including homes, garages, basements, sheds, boxes, pick-up truck beds, RV's, or boats. These spaces can trap poisonous gases, EVEN if you run a fan or open windows. If you start to feel sick, dizzy, or weak while using the air compressor, shut off the engine and get to fresh air RIGHT AWAY. See a doctor. You may have carbon monoxide poisoning.

Select a suitable outdoor location:

- Where it will NOT be exposed to rain, snow, or direct sunlight.
- Where no flammable vapors, dust, and gases are present.
- At least 7 feet away from combustable materials.
- Away from building windows or other air intakes.
- Away from other heat generating equipment.
- Away from dust condition.

Start-up Procedure:

- 1) Before Starting:
 - a) Drain storage tank and close drain valve.
 - b) Close regulator
- 2) Turn the unloader to the engine START position. (Figure XX)

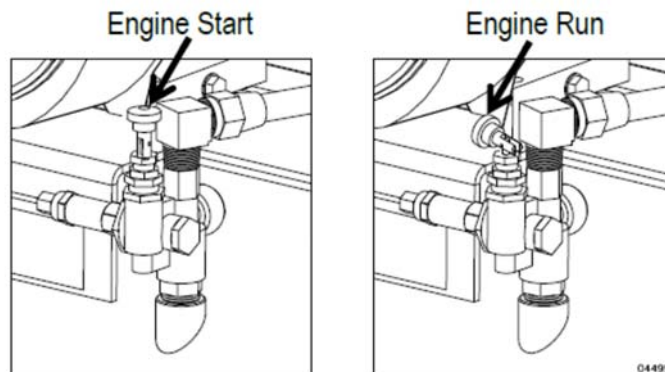

Figure XX

- 1) Starting engine. (See the engine owner's manual for more details.)
 - a) Turn the fuel shut-off valve (A) to the ON position. See Figure 6.
 - b) For a **Cold Engine** – Place the throttle control (A) midway between the **SLOW** and **FAST** positions. See Figure 7. Place the choke control (A) into the ON position. See Figure 8.

For a **Warm Engine (Normal Operating Temperatures)** – Place the throttle control (A) midway between the SLOW and FAST positions. A warm engine usually does not require the choke on. See Figure 7.

NOTE: The choke position for starting may vary depending upon temperatures and other factors. Once engine is running and warm, turn choke to the OFF position (A). See Figure 9.

- c) Start the engine as follows:
 - i) For Retractable Start Engine (Recoil) – Turn engine On/Off switch (A) to the ON position. See Figure 10.
 - ii) SLOWLY pull the starter handle (A) until just past compression – STOP! Return starter handle, and pull firmly with a smooth, steady motion to start. Pull the handle straight out to avoid excessive rope wear from the starter rope guide. See Figure 11.

NOTE: Extend the starting rope periodically and check its condition. If the rope is frayed, have it replaced immediately by your Kohler Engine Service Center.

- 2) Gradually return the choke control to the OFF position (A) after the engine starts and warms up. See Figure 9.

The engine/equipment may be operated during the warm-up period, but it may be necessary to leave the choke partially on until the engine warms up.

- 3) After the engine has started, move the unloader to the engine RUN position. See Figure XX.
- 4) Open the regulator and adjust it to the correct pressure setting.
- 5) The compressor is now ready to use.
- 6) The unloader will maintain pressure in the tank between 90 to 120 PSI.
- 7) Under long, continuous-run operating conditions, be prepared to:
 - a) Check the refuel on a regular basis. See engine owner's manual for more details.
 - b) Check engine oil level each time you refuel. See engine owner's manual for more details.

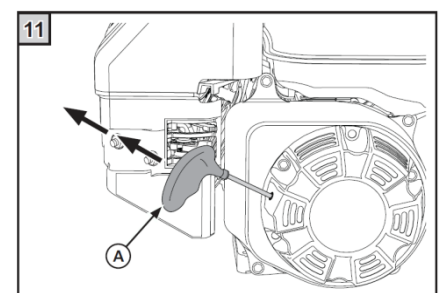
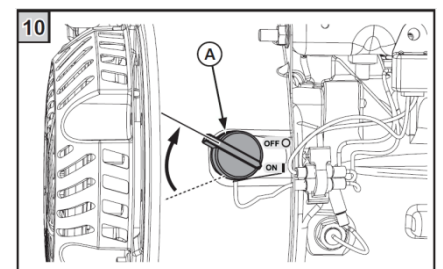
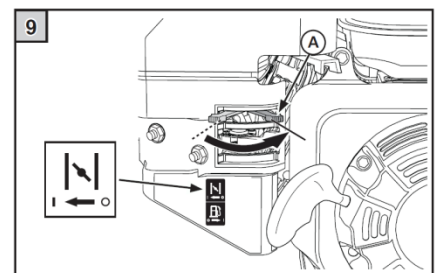
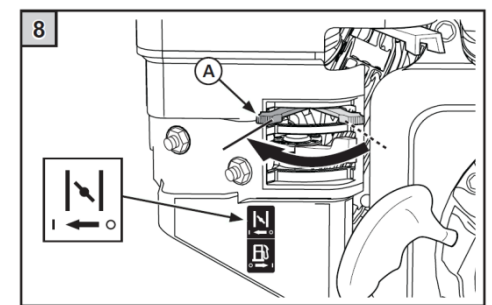
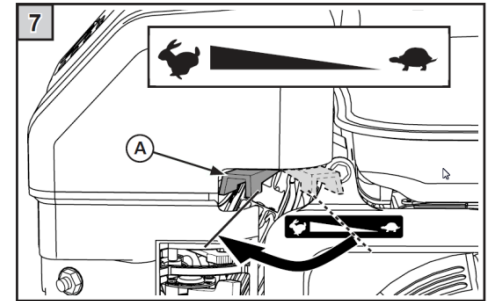
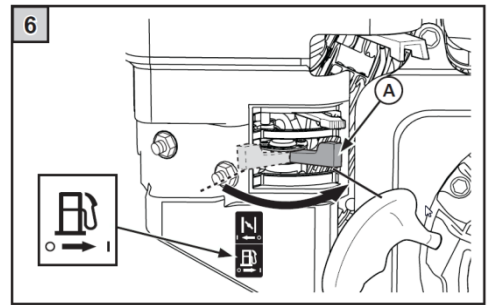



WARNING: Overheating



This compressor is not equipped with “auto shut off”. Do not allow to overheat. Failure to allow adequate ventilation or restrict air flow may cause the machine to overheat.



WARNING: Inflatables/Low PSI tire



Never use compressor to inflate small low-pressure objects, i.e. balloons/inflatables, small or low volume PSI tires. It is easy to over-pressurize them, causing them to rupture. Use a gauge to check the pressure regularly. Observe the inflation capacity of the object prior to filling with air.



WARNING: Bursting Hazard



Too much air pressure causes a hazardous risk of bursting. Check the manufacturer’s maximum pressure rating for air tools and accessories. The regulator outlet pressure must never exceed the maximum pressure rating.

Air Hose and Tool Use

Pressure control related devices. Never remove, adjust, bypass change, modify or make substitutions for safety/relief valves, pressure switches or other pressure control related devices. Over-pressurization of the compressor could result and cause explosion.



WARNING: Over-pressurize Hazard



NEVER over-pressurize the receiver tank or air tools beyond nameplate capacity. Do not operate the unit at pressures, temperatures or rotational speeds in excess of manufacturer’s recommendations. Be sure all accessory equipment and system components meet or exceeds the pressures and temperatures developed by the unit. Exceeding the pressure rating could cause them to explode or fly apart.

- Compressor and any tools must be sized properly – consider the maximum pressure requirements and air volume of each. (Maximum operating pressure of your compressor and volume rating is listed in the “Specifications” section of this manual.)
- Inspect hoses for holes or rupture points.
- Ensure the switch is in the OFF position and regulator pressure gauge reads zero before changing air tools or disconnecting hose from air outlet. Failure to do so could result in personal injury.
- All hose coupler/couplings and tool coupler/couplings must be installed prior to connecting hose to compressor.
- NEVER use air tools or attachments without first determining the maximum pressure recommended for that equipment.

! CAUTION: Incompatible Component Hazard !

Do not operate this unit with any components rated less than the maximum operating pressure of the unit unless a regulator limiting pressure is used.

- When using high-pressure tools, make sure the tool is properly coupled, user is wearing protective equipment, and there are no persons nearby.

Attaching Air Hose and Tools

! CAUTION: Air Tool Hazard !

Do not attach air tools to open end of the hose until start-up is completed and the unit checks out OK.

1. Connect air hose to quick connect fitting.
2. Connect tool to other end of the hose.
3. Keep fingers off trigger of tool until ready to use. A tool has power when compressor had air.
4. Ensure connections are tight/secure. Firmly grasp hose in hand when connecting or disconnecting to prevent hose whip. An improperly seated coupler can blow off the machine when started.

! WARNING: High Pressure Stream Hazard !

Never direct air stream at people or animals. A high-pressure stream produced by this compressor could pierce the skin and underlying tissue, leading to a serious injury or amputation. **DO NOT TREAT AN INJECTION INJURY AS A SIMPLE CUT!** In case of skin injection injury, see a physician immediately.

Note: To change tools or attachments, change out the tools on the end of the hose. There is a check valve built into the hose coupler so that air does not escape when tools are removed.

! WARNING: Projectile Hazard !

Never disconnect threaded joints with pressure in the tank. Removing threaded connections with pressure in the tank may cause the removed component to become a projectile.

- Do not string hoses across floors or aisles where they are liable to cause personnel to trip and fall. Suspend air supply hoses overhead, or otherwise locate to provide sufficient access and protection against damage.

Using Compressor for Spraying

Spraying flammable materials: Always follow precautions on container labels or MSDS (Material Safety Data Sheets) before spraying flammable materials such as paint.

Moisture in Compressed Air: Moisture in compressed air will form into droplets as it leaves air compressor pump. When humidity is high or when a compressor is in continuous use for an extended period of time, this moisture will collect in the tank. When using a paint sprayer or sandblast gun, this water will be carried from the tank through the hose, and out of the gun as droplets mixed with the spray material. If this is not acceptable for your application, an external air dryer must be added to the system.

Shutdown Procedures

Normal Shutdown

- 1) Move the pressure switch lever to OFF and turn regulator knob counter-clockwise to the stop/shut off air-flow.
- 2) Turn engine switch to OFF position.
- 3) Turn fuel valve lever to OFF position.
- 4) Drain air from the tank by releasing pressure. Disconnect hoses and open drain valves or pull the ring on the safety relief valve.

Note: Lifting the unloader knob will not release pressure from the tank.

- 5) Once the air tank pressure gauge registers under 10 PSI, open drain valves on the bottom of the tanks to drain any moisture.
- 6) Remove spark plug to prevent accidental starting of engine.
- 7) Cool engine at least 5 minutes before storing. A hot engine is a fire hazard. (See "Storage" section for more information.)

Malfunction During Operation.

Immediately turn off the compressor if any of the following conditions arise during operation:

- Excessive change in motor speed, slow or fast
- Overheating
- Excessive vibration
- Unusual noise
- Flame or smoke
- Air leakage

To stop the compressor in an emergency:

1. Move the pressure switch lever to the OFF and close the ball valve to stop/shut off air-flow.
2. Turn engine switch to OFF position.
3. Turn fuel valve lever to OFF/Closed position.
4. Pull the safety relief valve to quickly release pressure from the tank.
5. Remove spark plug to prevent accidental starting of engine.
6. Ensure compressor will not be restarted until problem is remedied.



WARNING: Shutdown Hazard



Do not leave an operating machine unattended. Always shut the machine OFF and relieve the pressure before leaving the machine. NEVER disconnect the high-pressure hose from the unit while the tank and air line is pressurized.

Maintenance



Importance of maintenance

Proper maintenance is critical for smooth operation of your air compressor and safety.

Below are guidelines including a maintenance schedule and inspection procedures. There are additional procedures that are more complicated or require special tools that are best performed by

certified technicians and qualified mechanics.

Improperly maintaining your air compressor or failing to correct a problem before use can cause malfunction that could cause serious injury or even death. Always follow the maintenance procedures and schedule.

	WARNING: Maintenance Hazard	
Always shut off engine, disconnect the spark plug wire from the spark plug and release air pressure from the receiver tank before cleaning, adjusting, or servicing the compressor. Make sure all guards and shields are replaced before re-starting.		

The maintenance procedures and schedule apply to “normal” operating conditions. If your air compressor is used more heavily or in extreme conditions (e.g. sustained high-load, high-temperature, dusty or wet environments), consult your Service Dealer for recommendations that are applicable to your specific needs and usage. Maintenance, replacement, and repair of your air compressor’s emission control devices and its systems can be performed by any engine repair establishment or repairperson, using parts that are certified to EPA standards.

Note: Your Authorized Service Dealer is knowledgeable about your air compressor, and is best equipped to maintain and repair it. To ensure smooth, economical, and trouble-free operations, use only new, genuine AXEMEN Power air compressor parts or their equivalents when repairing your air compressor and replacing its parts.

Maintenance safety precautions

Critical safety precautions are summarized below. Read the maintenance instructions before you begin and confirm that you have the necessary skills and proper tools to perform the procedures.

Since we couldn’t possibly warn you of every possible hazard that could arise while maintaining your air compressor, it’s essential that you use good judgment when deciding which procedures should be performed and use care when performing the procedures.

Turn air compressor off before servicing: Confirm that your air compressor’s Engine Switch is turned to the OFF position and remove the spark plug cap before beginning any maintenance and repairs.

Exhaust contains carbon monoxide: Never operate your air compressor in an enclosed or partially enclosed area. Be sure there is adequate ventilation. The engine exhaust contains carbon monoxide, a poisonous gas that is odorless and colorless. Be sure to have adequate ventilation when operating your air compressor and never allow the gas to build up.

Air compressors get extremely hot: To avoid severe burns always allow the engine and the exhaust system to completely cool before touching, moving, and storing.

Gasoline is flammable: Use extreme care when working with gasoline to avoid the possibility of fires and explosions. Use only nonflammable solvents when cleaning parts. DO NOT use gasoline to clean your air compressor's parts. Keep sparks, cigarettes, and flames away from all fuel, your air compressor, and any fuel-related components.

Guards and Shields: Make sure all guards and shields are replaced after servicing the air compressor.

Keep your air compressor upright: Never lay your air compressor on its side while moving, storing, or using it. Oil could leak and damage your air compressor's engine and surrounding areas.

Comply with local and current regulations: There may be local codes, ordinances, or federal or state Occupational Safety and Health Administration (OSHA) regulations that apply to the use of your air compressor. There may be additional regulations that apply if your air compressor is used on construction sites.

[Failure to follow maintenance precautions, procedures, and guidelines can cause you to be seriously injured or killed.]

Air Compressor Maintenance Schedule

Perform at indicated intervals		Regular service period (1)					
		Before each use	Weekly	First month	Every three months	Every six months	Every year
Start engine			●				
Engine oil*	Check	● (6)					
	Change		● (6)			● (6)	
Air filter Engine* and Compressor Pump	Check		● (6)				
	Clean				● (2)		
Sediment cup	Clean					● (3)	
Inspect safety/relief valves	Clean/Check	● (5)					
Spark plug*	Clean/adjust					● (6)	
	Replace						● (6)
Idle speed*	Check/adjust					●	

						(3)	
Spark arrestor* (optional part)	Clean					● (3)	
Fuel tank and filter*	Clean					● (3)	
Valve clearance	Check/adjust						● (3)
Combustion chamber*	Clean/adjust						● (3)
Cylinder*	Clean					● (3)	
Check for Air Leaks	Check		●				
Check Pump Oil Level	Check	●					
Change Pump Oil/Clean Drain Plug	Change/Clean			● (7)	● (7)		
Inspect & Drain Receiver Tank	Inspect and drain	●					
Check Drive Belt Tension and Alignment	Inspect and adjust		●				
Dust/Debris Removal	Inspect/remove	●					
Fuel line*	Serviced			● (4)			

NOTE: PLEASE REFER TO ENGINE MANUAL FOR MAINTENANCE SCHEDULE FOR ALL ENGINE MAINTENANCE.

* Emission-related items

Information about refueling can be found in the “Fuel Requirements” section.

Important maintenance considerations:

- (1) When used for commercial or heavier use, maintenance may be required at more frequent intervals.
- (2) Service more frequently when used in dusty areas.
- (3) These items should be serviced by an Authorized Service Dealer.
- (4) This should be serviced by an Authorized Service Dealer every three years.
- (5) Drain air compressor receiving tanks after each and every use.
- (6) Refer to engine manual for service of this item, first oil change after 5 hours of use, then every 100 hours.
- (7) After first 50 hours of use, every 3 months or 500 hours of use after that.

NOTE: Failure to follow this maintenance schedule could result in non-warrantable failures.

Detailed Instructions – Maintenance & Repair



NOTICE:



Dispose of used motor and pump oil in a manner that is compatible with the environment and in accordance with local, state, and federal laws and regulations.

- Take used oil in a sealed container to your local recycling center or service station for reclamation.
- Do NOT throw it in the trash, pour it on the ground, or pour it down the drain.

No Modifications. Never modify or alter the compressor in any way. Modifications can create serious safety hazards and will also void the warranty.

Inspect Safety/Relief Valve

This valve should be inspected on a Daily basis if used regularly or the first time it is being used after a prolonged period of storage. The safety valve automatically releases air if the tank pressure exceeds the preset maximum.

- Check the safety/relief valve by pulling the rings.
- Replace safety/relief valve that do not operate freely.



WARNING: Safety/Relief Valve Hazards



If the safety/relief valve does not work properly, over-pressurization may occur causing air tank rupture or explosion. Occasionally pull the ring on the safety valve to make sure the safety valve operates freely. If the valve is stuck or does not operate smoothly, it must be replaced with a valve having the same pressure rating. Please contact AXEMEN Power, Inc support for replacement parts.

Inspect Air Filter

Inspect the compressor's air filter elements on a Weekly basis if used regularly or the first time it is being used after a prolonged period of no use. A dirty air filter will not allow the air compressor to operate at full capacity.

- Clean air filters when necessary
- Every 12 months or 1000 hours, replace the air filter.

Note: Keep the air filter clean. Do not operate with the air filter removed. Operating the compressor without an air filter or dirty air filters will void the warranty.

Inspect Compressor for Air Leaks

Inspect system for air leaks on a Weekly basis, or again, at the first use after a prolonged period of storage.

- Squirt soapy water around joints during compressor operation and watch for bubbles. Developing bubbles indicate a leak is present.
- Tighten fittings if necessary.

Engine Maintenance

Perform engine maintenance as specified in the engine owner's manual. Items include:

- Change oil after the first 5 operating hours, and at least every 100 hours of use after that. Please refer to the engine owner's manual for details.

! !
WARNING: Burn Hazard
Never open oil port while compressor is running. Hot oil can spray over face and body.

- Air filters check/replacement.
- Spark plug cleaning/replacement.
- Fuel filter check/replacement.
- Fuel tank cleaning.

Change Pump Oil

After the first 50 hours of use the every 3 months or 500 hours, change pump oil while crankcase is still warm. (See "Appendix A: Lubricants" suitable alternatives.)

- 1) Remove the oil fill and drain plugs. Collect the oil in a suitable container.
- 2) Replace the oil drain plug and refill compressor crankcase with clean oil.
- 3) Replace the oil fill plug.
- 4) Start the unit and run for several minutes. Shut the air compressor down and check the oil level. If necessary, add more oil. (See Figure 8 at right.)

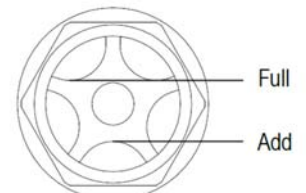

Figure 8

! !
WARNING: Air Tank Hazards
Failure to replace a rusted air receiver tank could result in tank rupture or explosion, which could cause substantial property damage, severe personal injury, or death. Never modify or repair a tank. Obtain replacement from service center by contacting customer support.

! !
CAUTION: Pulley/Sheave Hazard
Improper pulley/sheave alignment and belt tension can result in motor overload, excessive vibration, and premature belt and/or bearing failure. To prevent this from happening, check the pulley/sheave alignment and belt tension on a regular basis.

Belts will stretch from normal use. When properly adjusted, a 5 lb. force applied to the belt between the engine pulley and the pump will deflect the belt about 1/2".

To align and adjust drive belt tension:

- 1) Remove the belt guard.
- 2) Loosen the four fasteners holding the engine to the compressor.
- 3) Shift the engine in the proper direction, the belt must be properly aligned when adjustment is made.

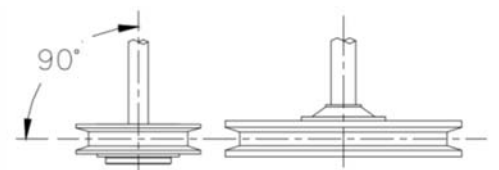

Figure 9

- 4) To align belt, lay a straight edge against the face of the flywheel touching the rim at two places. (See Figure 9 to the right)
- 5) Adjust flywheel or engine pulley so that the belt runs parallel to the straight edge.
- 6) If necessary, loosen set screw and use a gear puller to move the pulley on the motor shaft. Tighten set screw after pulley is positioned.
- 7) Check for proper belt tension. (See Figure 10)
- 8) Tighten the four fasteners holding the engine to the top plate while tension and alignment is maintained.
- 9) Attach the belt guard cover.

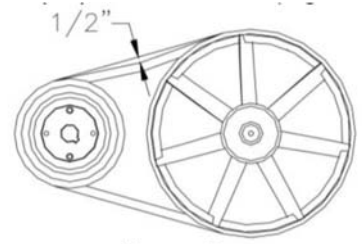

Figure 10

Inspect & Clean Spark Arrestor (If equipped)

Equip engine with spark arrestor if machine will be used near any ignitable forest, brush, or grassy land. (See engine owner's manual provided to determine if the engine is already equipped.) Make sure you comply with applicable local, state, and federal codes.

If the engine is equipped with a spark arrestor, clean and inspect it regularly following manufacturer's service instructions. Replace if damaged.

Keep Compressor Clean

Do NOT allow air intakes to become blocked. If dust or debris accumulates in the compressor, clean the compressor with a damp cloth or soft bristle brush.

Note: Do NOT spray compressor with a garden hose or pressure washer. Water may enter the compressor and cause damage to the engine and pump.

Storing and transporting your air compressor

Keep your air compressor upright at all times.



Never lay your air compressor on its side while moving, storing, or using it.

Oil could leak and damage your air compressor's engine and surrounding areas.

Between-Use Storage

Allow to cool: Your air compressor can get very hot when in use. A hot engine and exhaust system could cause severe burns and even ignite some materials. So, allow it to cool for at least fifteen minutes before moving or storing it.

Keep upright: To avoid damaging your air compressor and spilling fuel, the air compressor should

	WARNING: Risk of Bursting Hazard	
Drain air receiver tank daily or after each use to prevent moisture buildup in the tank. Serious injury or death may occur from a tank explosion if air tanks are not properly maintained.		

remain in an upright position at all times.

Turn OFF: Confirm that the Engine Switch is in the OFF position and turn the fuel shut off lever to the off/closed position and make sure that the Fuel Tank Cap is closed.

Drain the receiver tank: To prevent tank corrosion, drain the receiver tank after each days use. Draining the tank will:

- Dry out any moisture that has accumulated in the tank. Leftover moisture can cause tank corrosion and premature failure.
- Ensure that the unit is operating properly should it be needed in an emergency.

Remove Spark Plug Wire: When machine is not in use, remove spark plug wire to prevent unintentional starting or operation by untrained persons.

Protect your air compressor: Never drop your air compressor and protect it from getting damaged when using, transporting, or storing it. Never lay heavy objects on your air compressor.

Carefully select storage area: While in storage, your air compressor needs to be free of dust and not exposed to high-humidity conditions. Select a clean and dry area that is away from sources of heat, open flames, sparks, or pilot lights, even if gas tank is empty. Residual gasoline could ignite. Select area that is away from extreme high and low temperatures. So, examine the storage area closely to be sure it's an appropriate storage area.

Draining the Tank:

- 1) Reduce tank pressure below 10 PSI by disconnecting the hoses and opening the ball valve, or pulling the ring on the safety relief valve.

Note: Lifting the unloader knob will NOT release pressure from the tank.

- 2) Drain moisture from the tank by opening the drain valve located at the bottom of the tank.

Long Term Storage Preparation

Prepare engine for long-term storage if you will not be using the machine again for more than 30 days. Fuel can become stale when stored over 30 days. Stale fuel causes acid and gum deposits to form in the fuel system which can cause engine malfunction. Please refer to the engine owner's manual for storage procedures for the specific engine you have on your compressor. In general there are two options:

- a. Remove all gasoline from the tank and carburetor, see engine owner's manual
- Or
- b. Add fuel stabilizer to the gasoline as per the engine manufacturer owner's manual
 - c. Disconnect the spark plug wire and remove spark plug
 - d. Add one teaspoon of oil through spark plug hole.
 - e. Place rag over spark plug hole and pull the recoil starter handle a few times lightly to lubricate the combustion chamber.
 - f. Replace spark plug, but do not reconnect the spark plug wire.
 - g. Pull the recoil slowly until the highest resistance is felt.
 - h. Return the recoil handle gently.
 - i. Confirm all pressure is released from the receiving tank and the valves are closed.

Troubleshooting

Problem	Cause	Solution
Engine will not start	Fuel tank is empty.	Refill gasoline to proper level.
	Fuel shut-off valve is in OFF/closed position.	Move fuel shut-off valve lever to ON/Open position.
	Choke is in the OFF position.	Place the choke in the ON position unless the engine is warm.
	Engine On/Off switch is in the OFF position.	Turn the engine On/Off switch to the ON position.
	Spark Plug defective, dirty, or disconnected.	Check that spark plug wire is connected properly. Clean or replace spark plug with properly gapped spark plug.
	Spark plug wet with fuel (flooded engine).	Dry and reinstall spark plug. Start engine with throttle lever in FAST position.
	Bad fuel; Air Compressor stored without treating or draining gasoline, or refueled with bad gasoline.	Drain fuel and carburetor and refuel with fresh gasoline. Please contact customer service if you believe this could be the problem for instruction on a service center near you or further instructions.
	Low oil level caused by Oil Sentry to stop engine.	Add oil to proper level, see engine manual.
	Fuel filter clogged, carburetor malfunction, ignition malfunction, valves struck, etc.	Take engine to an authorized servicing dealer and/or contact customer service for instructions.

Engine lacks power	Air filter clogged	Clean or replace filter
	Throttle control is in the slow position	Move throttle control to fast position.
	Fuel filter clogged, carburetor malfunction, ignition malfunction, valves struck, etc.	Take engine to an authorized servicing dealer and/or contact customer service for instructions.
	Bad fuel; Air Compressor stored without treating or draining gasoline, or refueled with bad gasoline.	Drain fuel and carburetor and refuel with fresh gasoline. Please contact customer service if you believe this could be the problem for instruction on a service center near you or further instructions.

Air delivery drops off.	Air leak in discharge piping.	Check tubing connections, tighten joints or replace as required.
	Compressor components leaky, broken, loose.	Inspect components. Clean or replace as required.
	Loose flywheel or engine pulley, excessive end play in engine shaft or loose drive belts.	Check flywheel, engine pulley, crankshaft drive belt tension/alignment. Replace or repair as required.
	Clogged or dirty inlet and/or discharge line	Clean or replace.
	Defective safety/relief valve	Replace.
	Unloader leaks or does not work	Realign stem or replace.
	Leaking, broken, or worn inlet unloader parts at check valve.	Inspect parts and replace as required.

Compressor does not come up to speed or is slow to come up to speed.	Compressor pump oil viscosity is too high for ambient temperature	Drain existing lubricant and refill with proper lubricant.
	Belt tension too tight or sheaves not aligned.	Check tension/alignment.
	Loose flywheel or engine pulley, excessive end play in engine shaft or loose drive belts.	Check flywheel, engine pulley, crankshaft drive belt tension/alignment. Replace or repair as required.
	Clogged or dirty inlet and/or discharge line	Clean or replace.
	Defective safety/relief valve	Replace.
	Engine speed too slow.	Move throttle to FAST position.
Compressor will not unload cycle or will not unload when stopped.	Air leak in discharge piping.	Check tubing connections, tighten joints or replace as required.
	Clogged or dirty inlet and/or discharge line	Clean or replace.
	Unloader leaks or does not work	Realign stem or replace.
	Leaking, broken, or worn inlet	Inspect parts and replace as required.
Excessive starting or stopping.	Unloader leaks or does not work.	Realign stem or replace.
	Excessive condensation in receiver tank.	Drain receiver tank.
	Light duty cycle.	Increase duty cycle.
Moisture in crankcase, "milky" substance in oil.	Detergent lubricant in crankcase.	Replace with proper lubricant.

Oil in discharge air	Lubricant level too high.	Drain excess lubricant.
Safety/relief valve "pops".	Clogged or dirty inlet and/or discharge line	Clean or replace.
	Defective safety/relief valve	Replace.
	Unloader leaks or does not work	Realign stem or replace.
Low interstage pressure	High pressure inlet valve leaking	Inspect, clean, or repair as required.
High interstage pressure	Low pressure inlet valve leaking	Inspect, clean, or repair as required.

Air compressor specifications:

Model		TAC81M
Air compressor	Type	Gas Powered Portable Air Compressor
	Maximum Pressure Rating	120 PSI
	Volume Rating @ 90 PSI	14.2 cfm
	Receiver Capacity	8 Gallon
	Length	43 inches / 109 cm
	Width	26 inches/ 66 cm
	Height	32 inches / 81 cm
	Weight	180 lbs. / 81.8 kg.
Engine	Model	Kohler SH265
	Cooling system	Air-cooled
	Engine Speed (rpm)	3000-3300
	Displacement	196 cc
	Maximum output	4.9 KW
	Maximum torque (N-m)	11.5 N-m @ 2800 rpm
	Fuel	Unleaded
	Fuel Tank capacity	3.8 quarts / 3.6 liters
	Ignition	Transistorized pointless
	Starting system	Recoil starter
	Ignition system	Electronic intelligent ignition
	Spark plug: type and gap	Champion RC12YC or equivalent Spark plug gap: 0.03in (0.76 mm)
	Shaft Rotation	Counterclockwise
Supplies Required (buyer furnished)	Engine Oil	Refer to engine owner's manual
	Compressor Pump Oil	SAE 30 non-detergent pump oil non-synthetic (for first 50 hours of use), then drain and replace with synthetic. Synthetic SAE 30 non-detergent pump oil after first 50 hours of use.
	Pump Oil Capacity	27 oz. / 798.5 ml.
	Gasoline	Refer to engine owner's manual

Engine assembly and parts list:

(Please refer to the engine manual for the parts list and assembly diagram.)

Contact information for Technical and Customer Assistance

Locate an Authorized Service Dealer

For assistance in finding an Authorized Service Dealer, contact AXEMEN Power, Inc Customer Service at 1-888-929-3468 or Support@Axemenpower.com. Visit our web site at www.Axemenpower.com

Registration Card

Please fill out the registration card, and return back to us within 30 days of the purchase date. Registration card can be found in the same plastic bag as your manual.

Customer assistance

Authorized Service Dealers are trained professionals who are familiar with your air compressor. They can answer most of your questions and help you with any problems that you may encounter. If you are not satisfied with the service you received from your representative, ask to personally speak with the Service Manager or the Dealer's General Manager. The majority of questions and issues are resolved at the local Dealership.

However, if you are not satisfied with the information or response you received from your Service Dealer, you may contact AXEMEN Power Customer Service office:

AXEMEN Power, Inc
1701 Massey Tompkins Rd
Baytown TX 77521
www.Axemenpower.com

1-888-929-3468

When you contact us, please provide the following so that we may help you most effectively:

Your air compressor's model and serial numbers

Name of Dealer who sold the air compressor to you initially

Name and address of the Service Dealer who services your air compressor

Date you initially purchased your air compressor

Your name, address, and phone number

A detailed summary of the issue

Limited Warranty

AXEMEN Power air compressors are manufactured and distributed by AXEMEN Power, Inc. AXEMEN Power, Inc. shall warranty any piece of equipment manufactured, or parts of equipment manufactured, to be free from defects in material or workmanship for a period of 2 year from the date of purchase by user. This warranty applies to the original purchaser of the equipment and is non transferable. Verification of purchase is the responsibility of the buyer in the form of a sales receipt for the specific product. Parts will be replaced or repaired at no charge, except when the equipment has failed due to lack of proper maintenance or abuse. Any misuse, abuse, alteration or improper installation or operations will void warranty. Determining whether a part is to be replaced or repaired is the sole decision of AXEMEN Power, Inc.

NOTE: Some services performed by parties other than AXEMEN Power, Inc. may void warranty. Always contact AXEMEN Power, Inc. Customer Support at 1-888-929-3468 prior to having any service or warranty work performed, as some services performed by parties other than AXEMEN Power, Inc. approved service centers may void warranty.

This warranty covers parts only. It will not provide for replacement of complete products due to defective parts. Components not manufactured by AXEMEN Power, Inc. such as engines are guaranteed by their manufacturer and can be serviced at factory-authorized locations near you. The engine warranty is covered under the terms and conditions as outlined by the engine manufacturers warranty contained herein and is the sole responsibility of the engine manufacturer. Normal engine maintenance such as spark plugs, air filters, adjustments, fuel system cleaning and obstructions due to build up is not covered by this AXEMEN Power, Inc. warranty. AXEMEN Power, Inc. will not provide for replacement of complete products due to defective parts.

Any costs incurred due to replacement or repair of items outside of an AXEMEN Power, Inc. approved facility is the responsibility of the buyer and not covered under warranty. Transportation costs to and from service center is the responsibility of the buyer/customer. AXEMEN Power, Inc. can supply you with the service center location in your area by contacting AXEMEN Power customer support at the number below.

For warranty service, find the nearest Authorized Service Dealer by calling: 888-929-3468.

This warranty specifically excludes the following; failure of parts due to damage caused by accident, fire, flood, windstorm, acts of God, applications not approved by AXEMEN Power, Inc. in writing, corrosion caused by chemicals, use of replacement parts which do not conform to manufacturer's specifications, damage related to rodent and/or insect infestation, and damage caused by vandalism. Additional exclusions: loss of running time, inconvenience, loss of income, or loss of use, including any implied warranty of merchantability of fitness for a specific use. Also, outdoor power equipment needs periodic parts and service to perform well, and this warranty does not cover instances when normal use has exhausted the life of a component or the engine.

Warranty does not cover items subject to normal wear such as tires, receptacles or any part subject to direct physical contact by the public. This warranty does not cover any personal injury or damage to surrounding property caused by failure of any part. Repair or replacement of parts does not extend the warranty period.

THIS WARRANTY IS IN LIEU OF ANY OTHER WARRANTY EXPRESSED OR IMPLIED AND AXEMEN POWER INC. ASSUMES NO OTHER RESPONSIBILITY OR LIABILITY OUTSIDE THAT EXPRESSED WITHIN THIS WARRANTY.

THERE IS NO OTHER EXPRESSED WARRANTY. ANY AND ALL IMPLIED WARRANTIES ARE EXCLUDED. LIABILITY FOR CONSEQUENTIAL DAMAGES UNDER ANY AND ALL WARRANTIES ARE EXCLUDED TO THE EXTENT EXCLUSION IS PERMITTED BY LAW.

Please fill in the following information and have it on hand when you call in a warranty claim.

Customer Number: _____

Date of Purchase: _____

Serial Number: _____

Model Number: _____

Appendix A: Lubricants and Compatibility

The table to the right lists materials that are suitable or not recommended for use with synthetic oil. As some oil escapes into the compressed air, all components that come into contact with the air (i.e., piping, filters, hoses, tools, etc.) must be compatible with synthetic oil. AXEMEN Power recommends using synthetic oil after the first 50 hour break in period.

Alternate Lubricants:

You may use a petroleum based lubricant that is premium quality, does not contain detergents, contains only anti-rust, anti-oxidation, and anti-foam agents as additives, has a flashpoint of 440° F (227° C) or higher, and has an auto-ignition point of 650° F (343° C) or higher. See the petroleum lubricant viscosity table below. The table is intended as a general guide only. Heavy-duty operating conditions require heavier viscosities.

Refer specific operating conditions to AXEMEN Power, Inc Support at 1-888-929-3468 or Support@Axemenpower.com. Visit our web site at www.Axemenpower.com.

Suitable	Not Recommended
Viton®, Teflon®, Epoxy (Glass Filled), Oil Resistant Alkyd, Fluorosilicone, Fluorocarbon, Polysulfide, 2-Component Urethane, Nylon, Delrin®, Celcon®, High Nitrile Rubber (Buna N. NBR more than 36 Acrylonite), Polyurethane, Polyethylene, Epichlorohydrin, Polyacrylate, Melamine, Polypropylene, Baked Phenolics, Epoxy, Modified Alkyds	Neoprene, Natural Rubber, SBR Rubber, Acrylic Paint, Lacquer, Varnish, Polystyrene, PVC, ABS, Polycarbonite, Cellulose Acetate, Latex, EPR, Acrylics, Phenoxy, Polysulfones, Styrene Acrylonitile (San), Butyl
(© indicates trademark of DuPont Corporation)	

Temperature around Compressor	Viscosity Grade	
	ISO	SAE
Below 40°F (4°C)	60	20
40°F to 80°F (4°C to 27°C)	100	30
80°F to 100°F (27°C to 38°C)	150	40

