

AXEVAN

GAS PRESSURE WASHER



Congratulations on the purchase of your new pressure washer. In order to ensure you have the best possible experience please read through the following instructions. If you require any help please contact the customer service department at: (888)929-3468

Telephone

Contact us for assistance, we're here to help.



Table of Contents

1. Safety Advice.....	3
1.1 Definitions.....	3
1.2 Safety Warnings.....	3
1.3 Intended Application.....	7
2. Parts List.....	8
3. Assembled Model Diagram.....	10
4. Assembly Instructions.....	12
5. Operating Instructions.....	15
5.1 Using Spray Nozzle.....	15
5.2 Water Supply (Cold Water Only).....	15
5.3 Adjusting Water Pressure.....	15
5.4 Starting Pressure Washer.....	15
5.5 Cleaning with Detergents.....	16
5.6 Shutting Down and Cleaning Up.....	16
6. Engine Operation.....	17
6.1 Adding/Checking Oil.....	17
6.2 Adding Fuel.....	17
6.3 Starting Engine.....	18
6.4 Stopping Engine.....	18
7. Cleaning and Maintenance.....	18
7.1 Cleaning Water Inlet Filter.....	18
7.2 Engine Maintenance.....	18
7.3 Cleaning Carburetor.....	20
7.4 Cleaning the Spray Tips.....	20
7.5 Storing.....	20
7.6 Winterizing Procedures.....	21
8. Technical Specifications.....	21
9. Troubleshooting.....	22
10. Limited Warranty.....	24
11. Exploded Parts Diagram.....	25

1. SAFETY ADVICE

IMPORTANT: RETAIN FOR FUTURE REFERENCE AND READ CAREFULLY!

Do not attempt to install or operate this product until you have read the safety instructions in this manual. Safety items throughout this manual are labeled **Danger**, **Warning**, or **Caution** depending on the risk type.

Read and understand the operating manual and labels on the product. Familiarize yourself with the product application and limitations and the specific potential hazards. Know the controls and their proper use. It is important to know how to stop the product and disengage the controls quickly.

1.1 Definitions

 This is the safety alert symbol. It is used to alert you to potential personal injury hazards. Obey all safety messages that follow this symbol to avoid possible injury or death.

DANGER

Indicates an imminently hazardous situation which, if not avoided, will result in death or serious injury.

WARNING

Indicates a potentially hazardous situation which, if not avoided, could result in death or serious injury.

CAUTION

Indicates a potentially hazardous situation which, if not avoided, could result in minor or moderate injury.

TOXIC GASES

Alerts against possible toxic gases which can be harmful to your health or deadly if you are exposed to them.

FLAMMABLE AND COMBUSTIBLE MATERIALS

Alerts against the presence of materials/gases which can be extremely flammable.

POISONOUS

Alerts against materials/gases which are very poisonous and can cause serious bodily harm or even death.

IMPORTANT

Installation, operation, or maintenance information which is important but not hazard-related.

1.2 Safety Warnings

IMPORTANT

Never operate this product under the following conditions:

- If a noticeable change occurs in the engine speed
- If the engine misfires
- If there are flames or smoke in the area
- If there are excessive vibrations

DANGER

Read all safety warnings and all instructions. Failure to follow the warnings and instructions may result in fire and/or serious injury.

4 Safety Advice

1.2 Safety Warnings

⚠ DANGER—WORK AREA SAFETY AND EXHAUST FUMES

- Keep work area clean and well lit. Cluttered and dark areas incite accidents.
- Operate the product in a clean, dry and well-ventilated area.
- Do not operate the product in explosive atmospheres, such as in the presence of flammable liquids, gases or dust. Power tools create sparks which may ignite the dust or fumes.
- Never operate the product on a steep slope.
- Keep children, pets, and bystanders away from the operating area. Breathing exhaust fumes can cause serious injury or even death.
- Never start or run the engine indoors. The exhaust fumes are dangerous, containing carbon monoxide, an odorless and deadly gas. Operate this product only in a well-ventilated outdoor area

⚠ GASOLINE ENGINES PRODUCE TOXIC CARBON MONOXIDE EXHAUSTS FUMES. BREATHING CARBON MONOXIDE CAN CAUSE NAUSEA, FAINTING, OR DEATH.

⚠ WARNING—INADEQUATE VENTILATION

- Materials placed against or near the product, or operating the product in areas where the ambient temperature exceeds 40 °C (104 °F) (such as storage rooms or garages) can interfere with its proper ventilation features, causing overheating and possible ignition of the materials or buildings.
- Operate the product in a clean, dry, and well-ventilated area at least 2 m away from any buildings, objects, or walls.
- **NEVER OPERATE THIS PRODUCT INDOORS OR IN POORLY VENTILATED AREAS.**

⚠ CAUTION—HOT ENGINE AND MUFFLER

⚠ THE ENGINE AND MUFFLER BECOME VERY HOT DURING AND AFTER USE. AVOID TOUCHING THE ENGINE OR THE MUFFLER DURING OR AFTER USE.

⚠ WARNING—PERSONAL SAFETY

- Stay alert, watch what you are doing, and use common sense when operating a pressure washer. Do not use a pressure washer while you are tired or under the influence of drugs, alcohol, or medication. A moment of inattention while operating a pressure washer may result in serious personal injury.
- Use safety equipment. Always wear eye protection. Protective equipment such as A dust mask, non-skid safety shoes, A hard hat, or hearing protection used for appropriate conditions will reduce personal injuries.
- Do not use the product if the engine's switch does not turn it on or off. Any gasoline powered product that cannot be controlled with the engine switch is dangerous and must be repaired.
- Remove any adjusting key or wrench before starting the pressure washer. A wrench or a key left attached to a rotating part of the pressure washer may result in personal injury.
- Do not overreach. Do not operate the product while barefoot or when wearing sandals or similar lightweight footwear. Wear protective footwear that will protect your feet and improve your footing on slippery surfaces. Do not stand on the product. Keep proper footing and balance at all times. This enables better control of the product in unexpected situations.
- Avoid accidental starting. Be sure the engine's switch is off before transporting the product or performing any maintenance or service on the unit. Transporting or performing maintenance or service on a product with its switch on invites accidents.
- Dress properly. Do not wear loose clothing or jewellery. Keep your hair, clothing, and gloves away from moving parts. Loose clothes, jewellery, or long hair can get caught in moving parts.
- Do not place your hands or feet near moving parts.
- Do not use while on a ladder.

1.2 Safety Warnings

⚠ FLAMMABLE AND POISONOUS MATERIALS

- Gasoline is highly flammable and its vapors can explode if ignited. Take precautions when using fuel to reduce the chance of serious personal injury.
- When refilling or draining the fuel tank, use an approved fuel storage container while in a clean, well-ventilated outdoor area.
- Do not smoke or allow sparks, open flames, or other sources of ignition near the area while adding fuel or operating the product. Never fill fuel tank indoors.
- Equip the operating area with a fire extinguisher certified to handle gasoline or fuel fires.
- Keep grounded conductive objects, such as tools, away from exposed, live electrical parts and connections to avoid sparking or arcing. These events could ignite fumes or vapors.
- Always stop the engine and allow it to cool before filling the fuel tank. Never remove the cap of the fuel tank or add fuel while the engine is running or when the engine is hot. Do not operate the product with known leaks in the fuel system.
- Loosen the fuel tank cap slowly to relieve any pressure in the tank.
- Replace fuel tank and container caps securely and wipe up spilled fuel. Never operate the product without both caps securely in place.
- Avoid creating a source of ignition for spilled fuel. If fuel is spilled, do not attempt to start the engine near spill. Move the product away from the area of spillage and avoid creating any source of ignition until fuel vapors have dissipated.
- Store fuel in containers specifically designed and approved for this purpose.
- Store fuel in a cool, well-ventilated area, safely away from sparks, open flames, or other sources of ignition.
- Never store fuel or product with fuel in the tank inside a building where fumes may reach a spark, open flame, or any other source of ignition, such as a water heater, furnace, clothes dryer, or the like. Allow the engine to cool before storing indoors.

⚠ CAUTION—ENGINE SAFETY

- Certain components in this product and its related accessories contain chemicals which are known to cause cancer, birth defects, or other reproductive harm. Wash hands after handling.
- The engine exhaust from this product contains chemicals which are known to cause cancer, birth defects, or other reproductive harm.
- Check fuel lines, tank, cap, and fittings frequently for cracks or leaks. Replace if necessary.
- This engine was shipped without oil. Before you start the engine, make sure you add oil according to the instructions in this manual. If you start the engine without oil, it will be damaged beyond repair and will not be covered under the warranty.
- When starting engine ensure that spark plug, muffler, fuel cap and air filter are in place and secured.
- Do not crank engine with spark plug removed.
- If engine floods, move the throttle control to fast position and crank until engine starts.
- When operating the engine do not tip engine or equipment at an angle which will cause fuel to spill.
- Do not choke the carburetor to stop the engine.
- Never start or run the engine with the air cleaner assembly or the air filter removed.
- Transport or move the product only with empty fuel tank.
- Rapid retraction of starter cord (kickback) will pull hand and arm towards engine faster than you can let go. Risk of injury – broken bones, fractures, bruises, or sprains could result.
- Keep the engine and muffler free of grass, leaves, excessive grease, or carbon build-up to reduce the chance of a fire hazard.
- Do not tamper with any part of the engine to increase its speed.
- If the product makes an unusual noise or vibration, immediately shut off the engine, disconnect the spark plug wire, and check for the cause. Unusual noise or vibration is generally a sign of a problem.
- Use only attachments and accessories approved by the manufacturer. Failure to do so can result in personal injury.

6 Safety Advice

1.2 Safety Warnings

⚠ CAUTION—SPECIFIC SAFETY ADVICE

- Avoid dangerous conditions. Always operate this product on dry, solid and level ground.
- Never operate this product on slippery, wet, muddy, or icy surfaces. The operating area should be free from any obstructions. There should be plenty of room for handling, and the operator should stay alert at all times.
- Do not use this product in wet or damp areas or expose it to rain. Do not use it in areas where fumes from paint, solvents or flammable liquids pose a potential hazard.
- Inspect this product. Check before turning it on. Keep guards in place and in working order. Form a habit of checking to see that keys and adjusting wrenches are removed from tool area before turning it on.
- Replace damaged, missing or failed parts before using it. Make sure all nuts, bolts, screws, hydraulic fittings, hose clamps, etc. is securely tightened. Always check the oil level in the oil tank. Never operate this product when it needs to be repaired or when it is in poor mechanical condition.
- Never move or pull this product while spraying.
- Do not run the engine at a high speed when you are not using the product.

• **Risk of electric shock!** The water spray must never be directed towards any electric wiring, devices, or directly towards the pressure washer itself, or fatal electric shock may occur.



• **Risk of injury!** Do not direct the discharge stream at people. The high-pressure jet can be dangerous if misused, and therefore must not be directed at people, animals, electrical devices or the unit itself.



• **Risk of explosion!** When a combustible liquid is sprayed, there can be danger of fire or explosion, especially in a closed area. Therefore, do not spray flammable liquids. Do not use acids and solvents with this product either. These products can cause physical injuries to the operator and irreversible damage to the product.

• Learn how to stop the product and release the pressure quickly. Familiarize yourself with the controls.

⚠ CAUTION—SPECIFIC SAFETY ADVICE

• This product is capable of producing high pressure as rated in the **Technical Specifications**. To avoid rupture and injury, do not operate this product with components rated less than the unit itself (including but not limited to spray guns, hose, and hose connections).

⚠ WARNING—INJECTION HAZARD

• Equipment can cause serious injury if the spray penetrates the skin. Do not point the gun at anyone or any part of the body. In case of penetration, seek medical aid immediately.

⚠ CAUTION—SPRAY GUN

- The spray gun kicks back, so hold it with both hands.
- The trigger gun safety lock prevents the trigger from being engaged accidentally and it should be placed in locked position when not in use.

⚠ CAUTION—DETERGENTS

• This product has been designed for use with detergents that are specifically approved for pressure washer use. The use of other cleaning detergents may affect the operation

⚠ CAUTION—WATER CONNECTIONS

- For use with fresh and clean water only. Do not use this product with other liquids.
- To minimize the amount of water spraying back on the pressure washer, the device should be placed as far as possible from the cleaning site during use.
- The water supply system must be protected against backflow.
- Never use this product with water contaminated with solvents (e.g. paint thinners, gasoline, oil, etc.).
- Always prevent debris from being drawn into the product by using a clean water source and an additional water filter, if required.
- If this device is connected to a potable water system, the system must be protected against backflow.
- Suitable water temperature: 5°C (41°F) to 40°C (104°F).

1.2 Safety Warnings

CAUTION—SERVICE

- Before cleaning, repairing, inspecting, or adjusting, shut off the engine and make sure that all moving parts have stopped.
- Have your product serviced by certified repair personnel using only identical replacement parts. This ensures the safety of the product is maintained.
- Ensure proper maintenance. Check for misalignment or binding of moving parts, breakage of parts and any other condition that may affect the product's operation. If damaged, have the product repaired before use. Many accidents are caused by poorly maintained equipment.

IMPORTANT—COLD WEATHER START

- Do not operate this pressure washer in temperatures below 5°C. Operating pressure washer below 5°C may cause damage to the pump and other pressure washer parts.

IMPORTANT—SAFETY FEATURES

- **Thermal Relief Valve:** Protects the pump from overheating in case the nozzle gets clogged. This system should not be abused. Make sure the pump does not overheat.
- **Low-Oil Auto Shut-Off:** Protects the engine and prevents operating without proper lubrication. If the engine oil level goes below the recommended level, the pressure washer shuts off automatically.

CAUTION—PREVENT PUMP DAMAGE

- Do not run the engine for more than 5 minutes without pressing the wand trigger or damage to the pump might occur.
- Never let the engine run unless the product is connected to a water supply. Ensure water is running through the pressure washer before attempting to start the engine.
- Never run caustic fluids or acid through this product.

IMPORTANT—STORAGE

- Store the product in a well-ventilated area, with an empty fuel tank. Fuel should never be stored or placed near the product.
- When storing the product for winter, ensure that it is stored indoors (at room temperature), in a dry location away from any heat or ignition sources.
- If the product is to be stored with fuel in the fuel tank, add a fuel stabilizer (Product # 38-0907-6) to keep the gas from breaking down.
- To protect and extend the life of the product when storing it, use an antifreeze agent (Product # 039-8602) for the pump, which can be found at your local Canadian Tire store.

1.3 Intended Application







This product is designed for specific residential applications. Do not modify or use this product for any application other than the one it was designed for. Doing so will void the warranty.



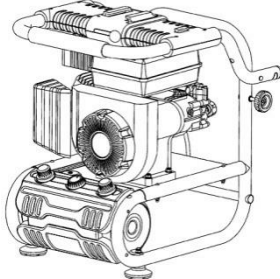

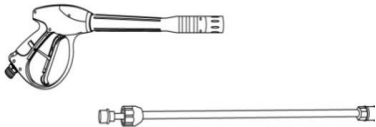



IMPORTANT—APPLICATIONS

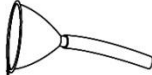

8 Parts List

2. PART LIST

Ref.	Description	Qty.	Visual
A	Main frame	1	 A detailed line drawing of the main frame assembly, which includes a central engine block, a fuel tank on the left, a spray gun on the right, and a protective metal cage structure.
B	Wheel with axle	2	 A line drawing of a single wheel with a central axle, featuring a tread pattern of small rectangular blocks.
C	Spray gun with metal wand	1	 A line drawing showing a spray gun with a trigger handle and a long, thin metal wand with a nozzle at the end.
D	High-pressure hose 30' (9 m)	1	 A line drawing of a coiled high-pressure hose, showing its flexible, braided texture.
E	Gun holster	2	 A line drawing of a protective holster designed to hold the spray gun.
F	Gun storage	1	 A line drawing of a storage container or case for the spray gun, shown with its lid open.
G	Hose hook	1	 A line drawing of a metal hook used to secure the end of the high-pressure hose.

Ref.	Description	Qty.	Visual	
H	Knob	2		
I	Bolt(M5x50), Washer(5), Nut(M5)	2sets		
J	Water inlet filter	1		
K	Accessory Kit	Spray tip cleaner	1	
L		Spare O-rings (two for high-pressure hose, one for quick-connect or)	3	
M		Oil funnel	1	
N		Wrench	1	
O		Spark plug wrench	1	
P		Screwdriver	1	

10 Assembled Model Diagram

3. ASSEMBLED MODEL DIAGRAM

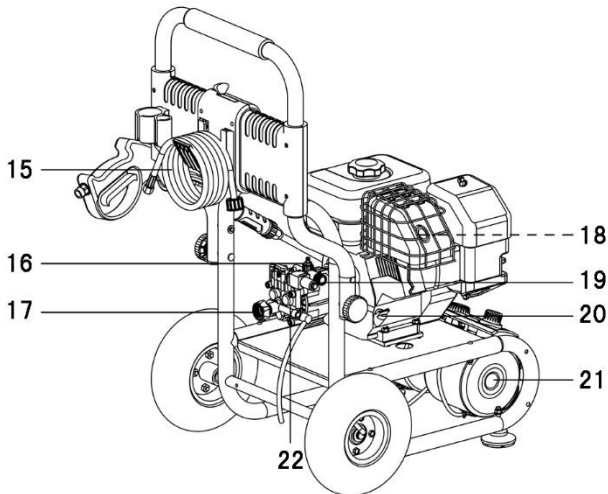
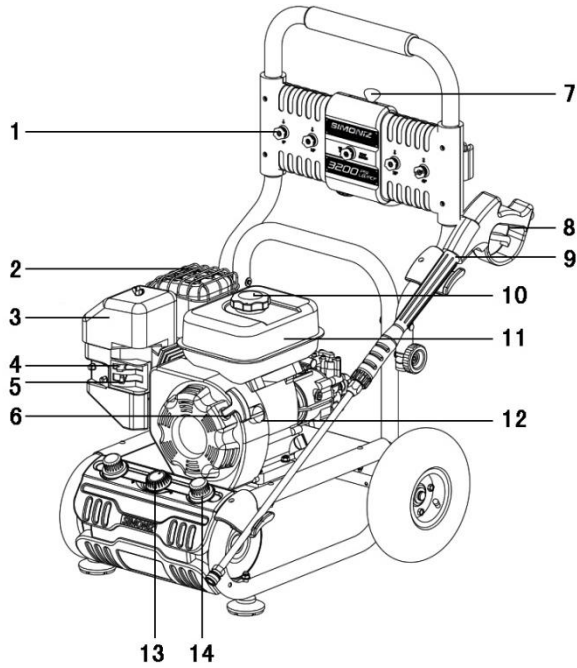

3. ASSEMBLED MODEL DIAGRAM

Ref.	Description
1	Spray nozzles(x5)
2	Muffler
3	Air filter
4	Choke lever (Close-Open)
5	Fuel valve (OFF-ON)
6	Start cord handle
7	Throttle lever (LOW-HIGH)
8	Trigger safety lock
9	Spray gun with wand
10	Fuel tank cap
11	Fuel tank

Ref.	Description
12	Engine I/Oswitch
13	Detergent dial
14	Detergent tank caps
15	Pressure hose 50' (15 m)
16	Pump detergent inlet
17	Pump Fresh Water Inlet 3/4" (2 cm)
18	Spark plug
19	Water outlet for pressure hose
20	Oil tank with dipstick
21	Detergent tank
22	Pump unit

Note: Engine oil is not included. Always use oil type **SAE 10W-30**.

12 Assembly Instructions

4. ASSEMBLY INSTRUCTION

1

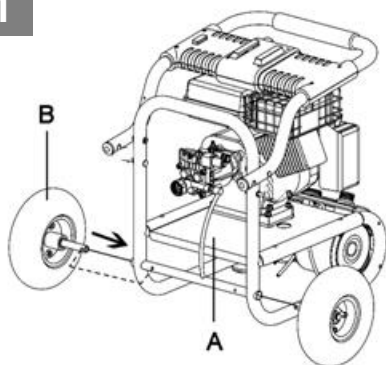

Wheel Assembly

NOTE: Make sure that there is enough air in wheel before assembly.

Lift the frame (A) with one hand and attach one of the wheels (B) by pressing the wheel's pin and inserting the wheel shaft into the main frame (A). Align the pin with the hole on the frame (A) until it snaps in. Repeat it for the opposite side.

2

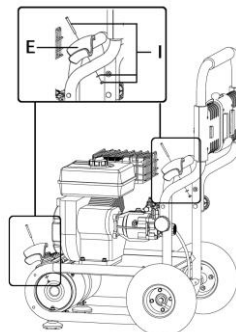

Gun Holster Assembly

Attach the two gun holster (E), one at the top and one at the bottom. Secure them with bolts, washers, nuts (I). Repeat this procedure for the upper one.

3

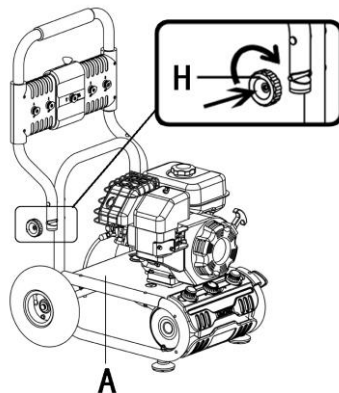

Frame Assembly

Insert knob (H) to frame (A) and secure clockwise. Repeat this procedure for the second knob (H) on the opposite side.

4

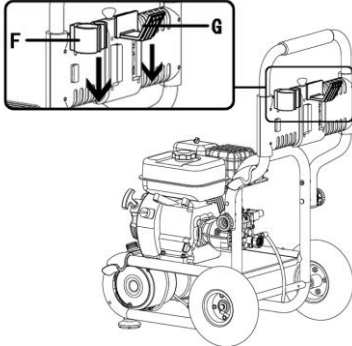

Gun Storage & Hose Hook Assembly

Attach gun storage (F) and hose hook (G) to the back of the panel. Push to the end until they slide into place.

5

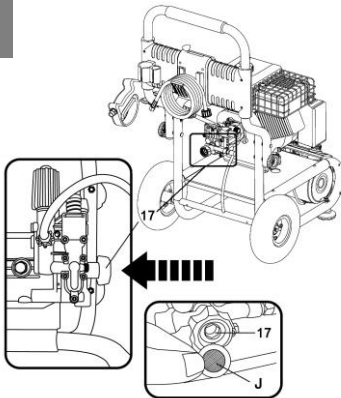

Hose Connection

Insert the water filter (J) into the plastic nut of pump inlet until it sits tightly in the nut. Attach one end of garden hose to pump inlet, and fasten the plastic nut counter-clockwise. Then attach the other end to water source.

6

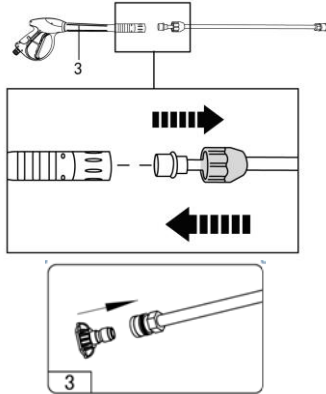

Gun/Wand Assembly

Assemble the spray gun with the wand. Pull back the rubber piece to expose the threaded fitting. Then, screw the two pieces together and move the rubber piece back. Insert the desired tip to the gun tip connector.

14 Assembly Instructions

7

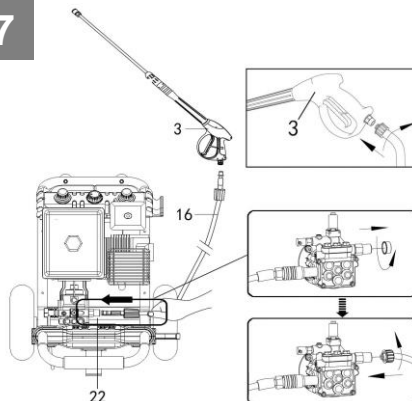

Gun & Hose Connections

Take out air shield from pump outlet. Connect one end of the high pressure hose to pump outlet, and secure the plastic nut. Connect the other hose end to pressure gun, and fasten the plastic nut.

Now your pressure washer is fully assembled.

⚠ CAUTION

Do not operate the product before you read and fully understand next chapter → Operating Instructions.

5. OPERATING INSTRUCTIONS

5.1 Using Spray Nozzle

This pressure washer comes with five different nozzles (1) that can be installed on the metal wand (9).

The spray pattern is adjusted by installing the appropriate spray nozzle.



0° (red): Thin and powerful stream of water for difficult stains and debris removal

15° (yellow): Thin-angled spray for detailed cleaning

25° (green): Medium-angled spray for detailed cleaning

40° (white): Large pattern for wider cleaning applications

Detergent (black): This nozzle must be used together with a cleaning detergent at a low pressure. Use only this nozzle when using a detergent.

Installing spray nozzle to the quick-connect coupler:

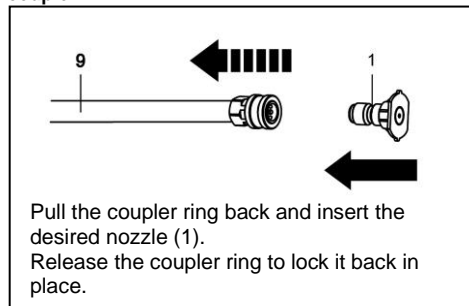

5.2 Water Supply (Cold Water Only)

• The unit must be used with cold water supply only. The water hose must be at least 1/2" (13 mm) in diameter.

• The water flow rate must not fall below 18 liters per minute (LPM) (4 gallons per minute (GPM)), or the pump might be damaged. The flow rate can be determined by running water for one minute into an empty container.

5.3 Adjusting Water Pressure

• The water pressure can be adjusted using the throttle lever (7).

• Move the throttle lever to **HIGH** position to increase the engine speed, thus increasing the water pressure. Move it towards **LOW** position to decrease the engine speed, thus decreasing the water pressure.

5.4 Starting Pressure Washer

• Detach the quick connector from pump water inlet and screw it on a garden hose then attach them to pump water inlet

Attach the other end of garden hose to water source.

• Turn on the water tap the water flow rate must not fall below 18 liters per minute (4 gallons per minute), or the pump might be damaged.

• Release the trigger safety lock (8) if it is locked.

Purge the air by squeezing the trigger on the gun until there is a steady stream of water.

• Install appropriate spray nozzle.

• Start the engine. (→ [Section 6.3 Starting Engine](#))

• Position the tip of the wand 6-8" (15-20 cm) away from the surface to be cleaned, at an angle appropriate to the spray nozzle used (**0°**, **15°**, **25°** or **40°**)

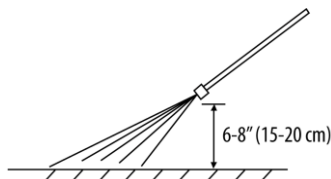

⚠ WARNING—INJECTION HAZARD

• Pressure washer can cause serious injury if the spray penetrates the skin. Do not point the gun at anyone or any part of the body. In case of penetration, seek medical aid immediately.

⚠ WARNING—DEPRESSURIZED

• After cleaning is completed, turn off the water supply and pull the trigger to depressurize the unit. Failure to do so might result in personal injury due to discharge of high-pressure water.

16 Operating Instructions

5.5 Cleaning with Detergents

IMPORTANT

This pressure washer is intended for use with special pressure washer detergents only. Do not use powdered soaps, which clog the injection system.

IMPORTANT

Working with a detergent ensures quick soaking of the dirt, and allows the high-pressure water to penetrate and remove the dirt more effectively. Always spray detergent on a **dry** surface, do not presoak the area. Soaking the surface dilutes the detergent and reduces its cleaning ability.

- When using detergent, always use the black detergent nozzle.
- When applying detergents, always operate the unit at a low water pressure (throttle lever (7) set to **LOW** position). This provides a gentle application of the detergent, with the water pressure equivalent to a garden hose. Always test the detergent in a concealed area before use.
- Pour two types of detergents into separate detergent tanks (21). It is recommended to have one detergent tank filled with all-purpose detergent, and the other filled with a more specific cleaning detergent, depending on the surface to be cleaned.
- The liquid detergent will be mixed with water automatically, and discharged through the detergent nozzle at a low pressure.
- Use the detergent dial (13) to control the type and amount of detergent used using the scale as reference.
- Set the detergent dial to OFF position in order to shutoff detergent supply.



- Allow detergent to remain on the surface for a short time before rinsing. Do not allow detergent to dry on the surface.

WARNING

Damage may occur to painted surfaces if chemicals (detergents) are allowed to dry on them. Wash and rinse a small section at a time. Avoid working on hot surfaces or under direct sunlight.

5.6 Shutting Down and Cleaning Up

1. Skip step 2 if you are not using detergent.
2. After cleaning with detergent, fill the detergent tank with clean water. Spray water at a low pressure for one minute, so that all detergent is flushed out of the system.
3. Stop the engine (→ [Section 6.4 Stopping Engine](#)).
4. Turn off the water supply and disconnect the water supply from the water inlet (17).
5. Point spray gun in safe direction, push trigger lock, and squeeze spray gun trigger to relieve retained high water pressure. Engage the trigger safety lock (8) on the spray gun.
6. Disconnect the garden hose from pump.
7. Disconnect the pressure hose from pump and pressure gun for storage. For long term storage instructions, see Instruction Manual.
8. Rewind the pressure hose and attach it to the hose hook.
9. Disconnect the gun and wand, and then insert them into upper gun holder.
10. Fold the handle and store.

NOTE : After turning off the machine, wait for 20 minutes to prevent plastic parts from being burned by muffler, then fold the handle.

WARNING

Turn off the water supply and pull the trigger to depressurize the unit. Failure to do so might result in personal injury due to discharge of pressurized water.

6. ENGINE OPERATION

6.1 Adding/Checking Oil

IMPORTANT

Oil has been drained for shipping. Failure to fill engine with oil before starting engine will result in permanent damage and will void engine warranty. Add oil according to the instructions.

WARNING

- Always check the oil level before starting the engine, making sure the pressure washer is on a level surface.
- Always use oil type **SAE 10W-30**, which can be found at your local **Canadian Tire** store (Product # 28-9301-6).

1. Remove oil tank dipstick (20) and wipe it with a clean cloth.
2. Replace and retighten the dipstick.
3. Remove the dipstick again and check the oil level. It should be at the top of the full indicator on the dipstick.
4. If low, add oil slowly into the oil tank. Do not overfill. After adding oil, wait one minute and then recheck the oil level.
5. Replace and retighten the dipstick.

Tip: When adding oil, use provided oil funnel (N).

10

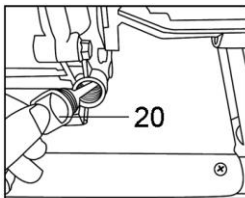

OIL TANK CAPACITY: 0.6L

6.2 Adding Fuel

WARNING

- Make sure there is enough fuel in the fuel tank before operating the pressure washer.
- Use only clean, fresh, unleaded fuel. Use a minimum of 87 octane/87 AKI (91 RON).
- Do not use old gas, and do not mix oil with gasoline.
- Fuel and its vapors are extremely flammable and explosive. Fire or explosion can cause severe burns or death.

1. Stop the engine (*→ Stopping Engine*) and let it cool at least two minutes before removing the fuel tank cap (10).
2. Clean the fuel cap area of dirt and debris. Remove the fuel tank cap and make sure the fuel filter is in place.
3. Fill the fuel tank (11) with fuel. Never overfill the fuel tank. Fill tank to no more than ½" (13 mm) below the bottom of the filler neck to provide space for expansion caused by the engine heat.
4. Replace the fuel tank cap.

11

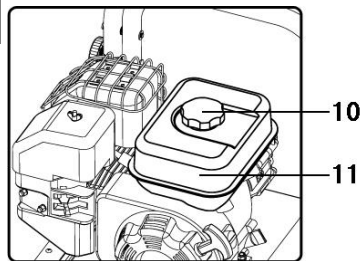

FUEL TANK CAPACITY: 3.6L

18 Operating Instructions

IMPORTANT

- Keep fuel away from sparks, open flames, pilot lights, heat, and other ignition sources.
- Check fuel hoses, tank, caps, and fittings frequently for cracks or leaks. Replace if necessary.
- If fuel spills, wait until it evaporates before starting engine.
- Fill the fuel tank outdoors or in well-ventilated areas.

6.3 Starting Engine

IMPORTANT

If you have problems starting the pressure washer, call the toll-free number (888)929-3468 and one of our customer service representatives will be glad to assist you.

IMPORTANT

Before each use:

- Check the oil and fuel level and fill if necessary.
- Make sure that spark plug, muffler, fuel cap, and air filter are in place and secured.
- Do not crank engine with spark plug removed.

See Section [5.4 Starting Pressure Washer](#) on Page 15 to start the pressure washer.

1. Turn engine switch to the “I” position.
2. Open fuel valve to the “ON” position.
3. Close the choke lever by moving the lever to the “CLOSE” position.
4. Adjust the throttle lever to “HIGH”
5. Locate recoil cord and pull slowly until resistance is felt. At this point, pull rapidly to start engine.
6. Once engine starts, open choke lever by moving the lever to “OPEN” position.

CAUTION

Return the starter cord handle (6) gently to its starting position to prevent damage to the starter or the housing.

6.4 Stopping Engine

1. Turn engine switch to the “ON” position.
2. Turn off fuel valve to the “OFF” position.

7. CLEANING AND MAINTENANCE

7.1 Cleaning Water Inlet Filter

- This pressure washer is equipped with a water inlet filter (J).
- The water inlet filter (J) must be kept clean at all times; otherwise it can restrict the water flow to the

pump unit and damage it.

- Remove the quick-connect coupler from the water inlet, then remove and clean the water inlet filter (J).

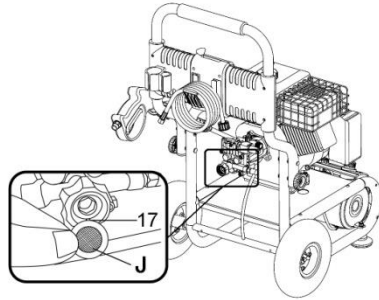

CAUTION

DO NOT operate this pressure washer without the water inlet filter in place, as deposits could build up internally and affect the functioning of the unit.

7.2 Engine Maintenance

Draining Engine Oil

The engine oil should be replaced after the first 20 hours of operation, or after the first month of use. After that, it should be replaced every 100 hours or every six months.

To drain the engine oil:

1. Loosen the oil tank dipstick (20).
2. Place an oil container underneath the opening on the mainframe.
3. Remove the hex screw and drain the oil.
4. Once the oil has been completely drained, retighten the hex screw and oil tank dipstick.

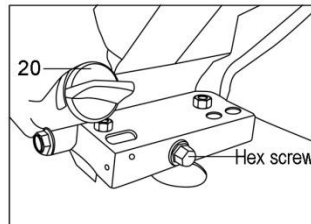

Recommended Engine Oil

Add oil as described in chapter → [Adding/Checking Oil](#).

20 Engine Operation/Cleaning and Maintenance

➤ IMPORTANT

Used oil is a hazardous waste product and must be disposed of properly. Do not discard with household waste. Check with your local authorities, service centre, or **Canadian Tire** for safe disposal/recycling facilities.

Checking Air Filter

➤ IMPORTANT

Clean air filter (3) element after every 50 hours of use (every 10 hours under dusty conditions). Wash in high flashpoint solvent, squeeze dry, dip in clean engine oil, and squeeze out excess oil.

12

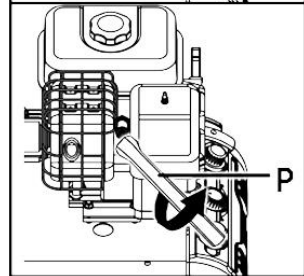
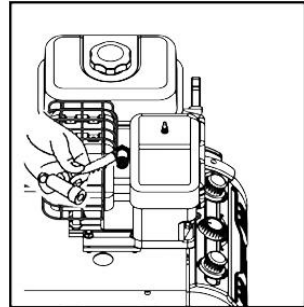
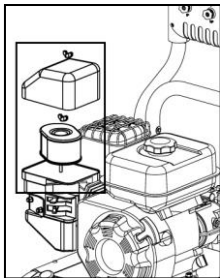

3. Check the gap with a wire gauge. If necessary, reset the gap to 0.7-0.8 mm. Install and tighten the spark plug to the recommended torque—180 lb-in (20 Nm).
4. Reinstall the spark plug wire and protection cage in reverse order.

Inspecting, Replacing or Cleaning the Spark Plug

The spark plug should be checked after every 100 hours of operation or every six months.

To replace or clean the spark plug:

1. Disconnect the spark plug wire by pulling it off the spark plug.
2. Using provided spark plug wrench (P), remove the spark plug by turning it counter-clockwise. If there is a carbon sediment build-up, remove it. If there is too much carbon sediment, replace the spark plug.

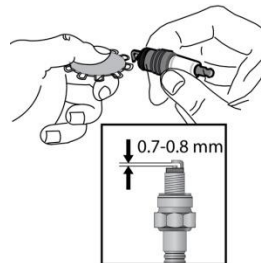

NOTE: In some areas, local law requires using a resistor spark plug to suppress ignition signals. If this engine was originally equipped with a resistor spark plug, use the same type for replacement.

7.3 Cleaning the Carburetor

1. Turn the fuel valve to **OFF** position.
2. Screw down the bolt on the bottom of carburetor with wrench.
3. Push the float up four to five times, then clean sediment cup with gas.

NOTE: Put the sediment cup back. Be careful not to miss the O ring.

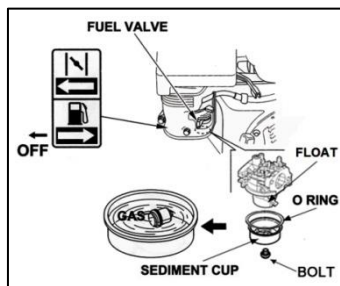

7.4 Cleaning the spray tips

⚠ WARNING

Clogging of the spray tip increases the water pressure and might damage the pump unit (22).

Clean the spray tip by carefully inserting the provided spray tip cleaner (K), or a thin, sharp object (e.g., paper clip) into the tip to remove deposits.

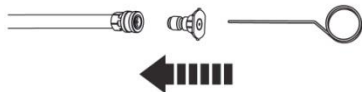

7.5 Storing

Store idle product out of the reach of children and do not allow anyone unfamiliar with the product or these instructions to operate it. This product is dangerous in the hands of untrained users. Cover and store indoors, in a dry, well-ventilated area, such as a tool-shed. Long term storage of the pressure washer requires additional preventive measures to protect it against deterioration.

1. Drain fuel

• Move the fuel valve (5) to **OFF** position and remove the hex screw from the carburetor. Then, move the

fuel valve to **ON** position to drain the fuel from the tank, carburetor, and hose. Screw the carburetor drain hex screw back once the fuel has been completely drained.

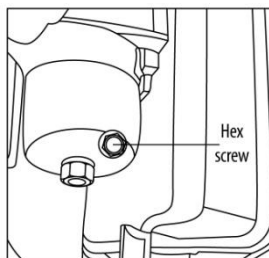

2. Add fuel stabilizer

• If you do not wish to drain the fuel tank (11), add a fuel stabilizer into the fuel tank. Run the engine at least five minutes after adding the stabilizer to distribute it inside the fuel system.

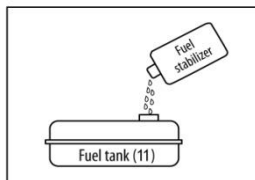

3. Drain oil

- Drain the oil (→ [Draining Engine Oil](#)).
- Remove the spark plug.
- Pour one tablespoon (14 ml) of **10W-30** oil through the spark plug hole.

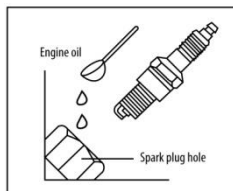

- Make sure the engine **I/O** switch (12) is set to **ON** position. Slowly pull the starter cord handle (6) until you feel tension, which indicates the piston is on its compression stroke and leave it in this position.
- Replace the spark plug.

22 Cleaning and Maintenance

7.6 Winterizing Procedure

- Pressure washer might be damaged if subjected to freezing temperatures. This type of damage is not covered by the limited warranty. To avoid possible damages, use a small amount of antifreeze.
- Place the pressure washer on its side, with the water inlet (17) facing upwards, and pour 1/4 cup (60 ml) of antifreeze into the water inlet.
- Make sure the engine I/O switch is set to **ON** position and pull the starter cord handle several times to distribute the antifreeze inside the pump system.
- When taking the pressure washer out of storage, run water through the system until it runs clear.

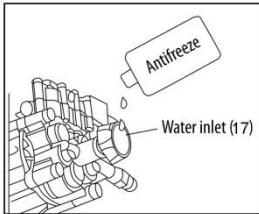

Maximum Pressure	3000 PSI
Rated Water Pressure	2500 PSI
Maximum Water Flow	10 liters per minute (LPM) (2.6 gallons per minute (GPM))
Minimum Inlet Pressure	30 PSI
Maximum Inlet Pressure	100 PSI
Pump Type	Heavy-duty, maintenance-free axial
Thermal Relief Valve	Included
Detergent Tank (Volume)	0.5 × 2g (2.25x2 L)
Maximum Temperature of Pumped Water	104°F(40°C)
Engine Power (OHV)	6.5 HP
No Load Speed	3600 RPM
High Pressure Hose Length	50' (15 m)
Inlet & Discharge Ports	3/4" (13 mm) standard garden hose connector
Displacement	196 (cc)
Net Weight	82 lb 10 oz (37 kg)
Oil Type	SAE 10W-30
Oil Capacity	0.6 L
Fuel Type	Unleaded Gasoline
Fuel Tank	3.8 L

CATIONS

- IMPO**
- If the press gasoline in t important to ignition.
 - Select a w any applian furnace, wat any area wit where powe
 - If possible, because tha
 - Place the p Tilting can c
 - Do not use nonporous o pressure wa

8.

TEC

HNIC

AL

SPE

CIFI

9. TROUBLE SHOOTING

PROBLEM	POSSIBLE CAUSE	SOLUTION	
Engine	The engine power switch is in OFF (o) position	Ensure the switch is in ON (I) position	
	No fuel	Fill the fuel tank with regular gasoline	
	Low oil shut down sensor tripped to protect engine (not applicable to SKU#039-8563-2 2600 psi pressure washer)	Add oil until it reaches minimum level on dip stick	
	Excess water pressure in pump or hose	Release water pressure by squeezing trigger on gun	
	Choke lever not in right position	1. When cold starting the engine, set the choke to CLOSE or OFF . 2. When warm starting, set the choke to OPEN or ON or try the middle position.	
	Clogged carburetor	Clean the carburetor. Refer to the instruction manual	
	Carbon build-up on spark plug	Clean the spark plug. Refer to the instruction manual	
	Incorrect starting method	Use correct starting method. Refer to the instruction manual	
	Engine stops after starting	Low oil or no fuel	Check oil and fuel levels
		Choke lever in Close position	Move the choke lever to Open position immediately after starting the engine
	Engine lacks power	Clogged air filter	Clean or replace the air filter. Refer to the instruction manual
		Clogged carburetor	Clean the carburetor. Refer to the instruction manual
	Engine stops while moving or being tiled	Low oil shut down sensor tripped to protect engine (not applicable to SKU#039-8563-2 2600 psi pressure washer)	Do not tilt the machine past 15° when operating. Check oil level and ensure it is above the minimum level on the dip stick
	Carburetor leaks	Carburetor is clogged	Clean the carburetor. Refer to the instruction manual
	Starter rope doesn't recoil	Recoil mechanism is broken	Call customer service toll-free
Engine sounds abnormal or overloaded	RPM too low (not applicable to SKU#039-8563-2 2600 psi pressure washer)	Adjust throttle lever to Fast position	
	Clogged nozzle	Clean nozzle with tip cleaner	
	Pressure is too high	Call customer service toll-free	

24 Trouble Shooting

PROBLEM		POSSIBLE CAUSE	SOLUTION
Pump	No pressure, low pressure	Nozzle tip not attached	Attach required nozzle tip
		Water supply faucet closed	Turn on faucet. Ensure there are no kinks or blockage in hose
		Water supply pressure is low	Ensure faucet is fully opened. Check to make sure water supply is a minimum 30 psi, 4 GPM
		Inlet water filter is clogged	Clean the water filter. Refer to the instruction manual
		Air in pump	Squeeze trigger to release the air in pump when the machine is running
		The loaded RPM is not set to FAST (not applicable to SKU#039-8563-2 2600 psi pressure washer)	Set RPM (throttle lever) to FAST position
		Clogged check valve	Call customer service toll-free
		Damaged pump	Call customer service toll-free
	Pressure too high	Clogged nozzle	Clean nozzle with tip cleaner
	Water or oil leaks out of pump	Damaged seal ring	Call customer service toll-free
	Cold water keeps draining out of thermal relief valve	Defective thermal relief valve	Call customer service toll-free
	Accessories & Connections	No intake of detergent	The detergent siphon tube is not connected
Damaged detergent siphon tube			Replace the detergent siphon tube
Wrong nozzle			Use black nozzle when applying detergent. Refer to the instruction manual
Detergent adjustment knob set to wrong position			Check adjustment knob. Refer to the instruction manual
Clogged nozzle			Clean nozzle
Clogged pump detergent siphon fitting			Detach the detergent siphon tube and clean the fitting with tip cleaner
Detergent is too thick. Clogged detergent filter			Use only detergent approved for use with pressure washer
Only applies to SKU#039-8563-2 2600 psi pressure washer			Clean detergent filter
The trigger can't be squeezed		Safety lock is not open	Open the safety lock. Refer to the instruction manual
There is water leakage at joints/connections on gun, hose and/or pump		Damaged seal ring	Change with back-up O-ring or purchase accessory kit SKU#.039-8552-8 at local Canadian Tire Store [®]
High pressure hose can't be connected to pump or gun		The O rings are not lubricated	Put lubricating oil or water on the O rings

10. LIMITED WARRANTY

Always keep your receipt as proof of purchase.

We're here to help! If you have any questions or comments, call our toll-free hotline (888)929-3468. Have your serial number ready. The serial number can be found on the back plate, located on the rear of the unit.

This product has a Parts Replacement, Product Exchange and/or Repair Warranty only. **NO REFUNDS** will be provided. Please see stores for Product Exchange details.

Two-Year Warranty – Motor

This product is guaranteed to be free from defects in material and workmanship for two years from the date of its original purchase. If such a defect appears during the warranty period, upon presentation of proof of purchase, Twinleaf Distribution will repair or replace the product (at its discretion). Shipping charges may apply.

Sixty-(60)-Day Warranty – Accessories

Trigger gun, hose, spray wands and other accessories are guaranteed for 90 days from the date of purchase. You may purchase accessories directly through the place of purchase or by calling our toll-free hotline (888)929-3468

This warranty does not cover accidental damage, unreasonable use, normal wear and tear, use of improper detergents, freezing, neglect or non-compliance with the operating instructions. The warranty does not cover loss of use or other consequential damages arising from any of the above, nor does it cover repairs made or attempted by unauthorized persons.

The warranty is void if the equipment is used for commercial, rental, or industrial purposes.

26 Trouble Shooting

11. EXPLODED PARTS DIAGRAM

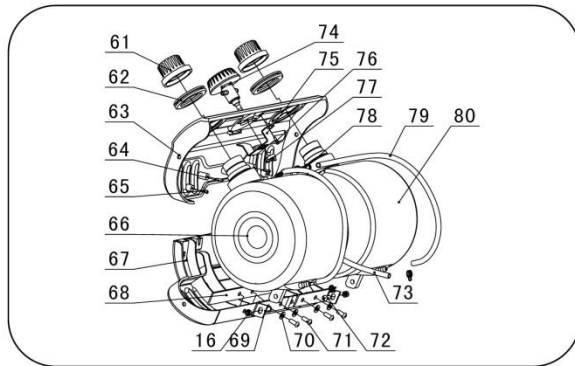
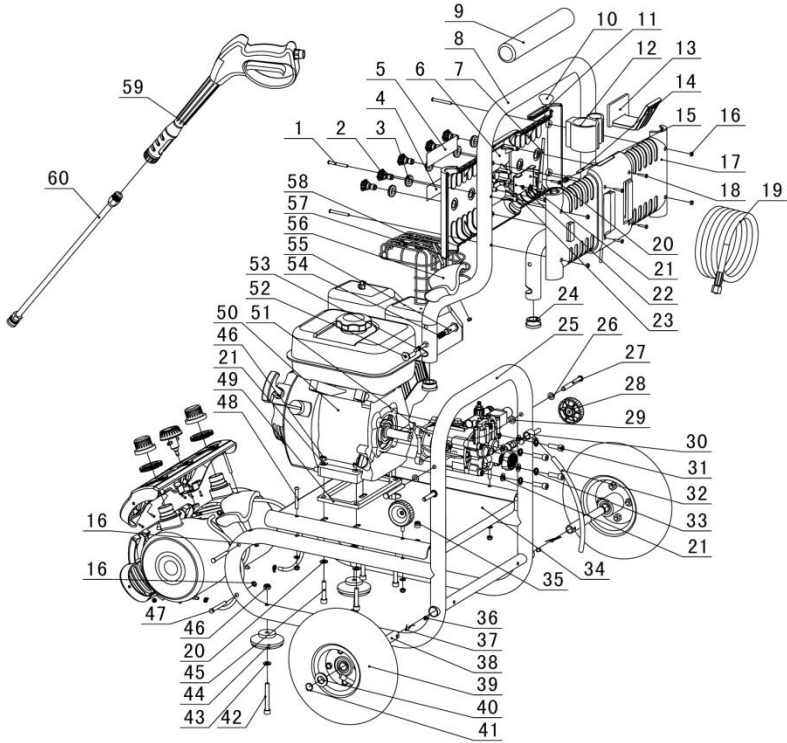

Exploded Parts Diagram 27

Ref. #	Description	Qty.
1	Cross Pan Head Screw M5x45	8
1-2	0° Nozzle (red)	1
2-2	15° Nozzle (yellow)	1
3-2	25° Nozzle (green)	1
4-2	40° Nozzle (white)	1
5-2	Detergent Nozzle (black)	1
3	Nozzle Grommet	5
4	lower metal plate	1
5	upper metal plate	1
6	Front Panel	1
7	Throttle Lever Adjust	1
8	Handle	1
9	Foam	1
10	Throttle Lever Adjust cap	1
11	ruber strip	1
12	Gun Storage	1
13	Hose Hook	1
14	Brake Line	1
15	Protecting Sleeve	1
16	Hexagon Nut M5	12
17	Rear Panel	1
18	Cross Pan Head Tapping Screw ST4x20	4
19	High Pressure Hose	1
20	Cross Pan Head Tapping Screw ST4x10	4
21	Plain Washer φ8	21
22	Throttle Lever Positioning Plate	1
23	Rivet	1
24	Plug φ32	2
25	Frame	1
26	Washer	4
27	Rotation Shaft	2
28	Knob Component	2
29	Circlip φ8	2
30	Over Flow Valve Cap	1
31	Inner Hexagon Bolt M8x25	4
32	Drain Pipe	1
33	Spring Washer φ8	4
34	Baseboard	1
35	Protecting Sleeve	2
36	Clip	2
37	Spring Wire	2
38	Wheel Axle	2

Ref.#	Description	Qty.
39	10" Air Wheel	2
40	Plain Washer φ16	2
41	Circlip φ16	2
42	Inner Hexagon Bolt M8x45	2
43	Rubber Foot Gasket	2
44	Rubber Foot φ70	2
45	Inner Hexagon Bolt M8x45	4
46	Locknut M8	6
47	Cross Pan Head Screw M5x45	4
48	Cross Pan Head Screw M6x45	4
49	Engine Isolator	1
50	6.5HP KOHLER Engine	1
51	High Pressure Pump	1
52	outer locating part	1
53	locating pin	1
54	spring	1
55	inner locating part	1
56	Gun Holster	2
57	Cross Pan Head Screw M5x50	2
58	muffler guard	1
59	Gun	1
60	Wand	1
61	Detergent Bottle Cap	2
62	Detergent Bottle Gasket	2
63	detergent bottle panel A	1
64	Cross Pan Head Tapping Screw ST4x16	3
65	Cross Pan Head Tapping Screw ST4x8	2
66	Detergent Bottle B	1
67	Detergent Bottle Panel	1
68	detergent bottle fixing plate(L)	1
69	detergent bottle fixing plate(S)	1
70	Plain Washer φ5	4
71	Cross Pan Head Screw M5x12	4
72	Cross Pan Head Screw M5x16	2
73	Injection Hose 850mm	1
74	Detergent Adjust Switch Assy	1
75	Adjust Switch Plate	1
76	Cross Pan Head Screw M4x10	1
77	Adjust Switch Nut	1
78	Injection Hose Clip	5
79	Injection Hose 310mm	2
80	Detergent Bottle A	1